

# Installation Instructions

Domestic hot water storage calorifier  
S 150, 200, 300



**Keep these instructions**

# 1. General

The ST 150, 200, 300 domestic hot water storage calorifiers are delivered fitted.

Only the calorifier hood and the adjustable screw-on feet delivered must be fitted.

The Service Instructions (delivered with the replacement anode) describe how to check\* and replace the magnesium anode.

\* with an anode checking device between the main checks every two years.

## Contents

## Page

1. General . . . . .	2
2. Dimensions and connections . . . . .	2
3. Delivery . . . . .	3
4. Transportation . . . . .	3
5. Setting up . . . . .	4
6. Fitting . . . . .	4-5
Installation . . . . .	4
Fitting the sensor . . . . .	5
Magnesium anode . . . . .	5
7. Putting into operation . . . . .	6
8. Maintenance . . . . .	6-7

# 2. Dimensions and connections

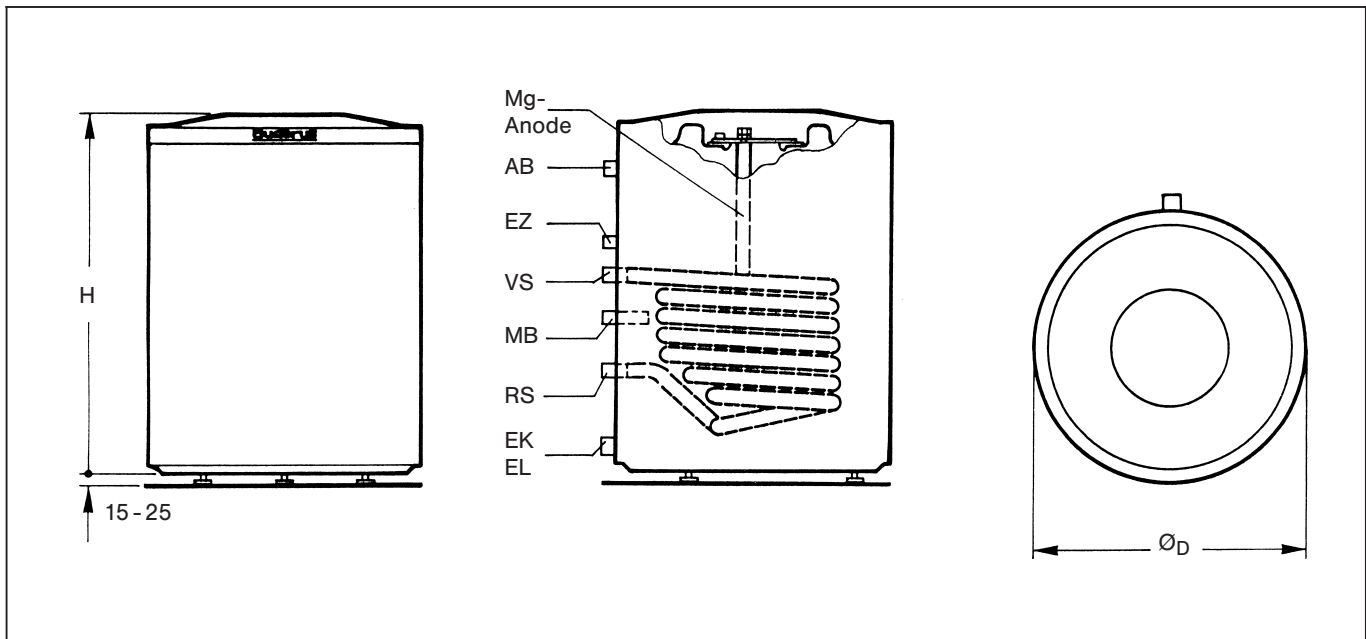

Fig. 1

Type	Ø D mm	H mm	AB	VS	RS	EK / EL	EZ
150	672	880	R 1	R 1	R 1	R 1 <sup>1</sup> / <sub>4</sub>	R 3 <sup>3</sup> / <sub>4</sub>
200	672	1075	R 1	R 1	R 1	R 1 <sup>1</sup> / <sub>4</sub>	R 3 <sup>3</sup> / <sub>4</sub>
300	672	1465	R 1	R 1	R 1	R 1 <sup>1</sup> / <sub>4</sub>	R 3 <sup>3</sup> / <sub>4</sub>

### Symbols:

- AB = Domestic water outlet
- VS = Calorifier flow
- RS = Calorifier return
- EK = Cold water inlet
- EL = Drain
- EZ = Circulation inlet
- MB = Domestic water measuring point

### 3. Delivery

Storage tank with foamed insulating casing, storage tank hood (laid on loosely).

Screw-on feet (hexagonal head screws) and accessories in the packing lid.

### 4. Transportation

The calorifier can be transported packed or unpacked with the Buderus boiler trolley\* (Fig. 2).

\* = can be ordered as accessory

- Remove the plastic foil.
- Remove the accessories sack and the screw-on feet from the packing lid.
- Remove the packing lid and lay it on the ground as a support (Fig. 3).
- Remove the calorifier hood.
- Tilt the calorifier over the edge of the bottom pallet and lay it on its side on the packing lid (Fig. 3).
- Remove the bottom pallet.
- Screw 3 screw-in feet into the bottom of the storage tank and leave them protruding approx. 20 mm (Fig. 3).
- Move the calorifier to the installation location.

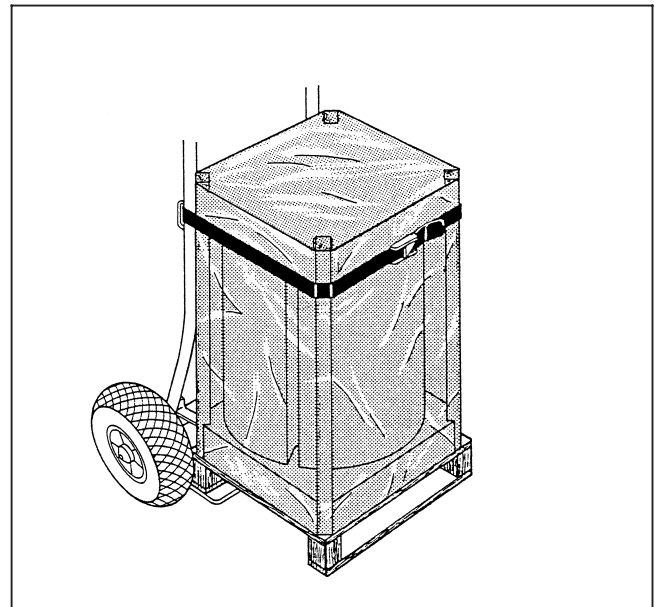

Fig. 2

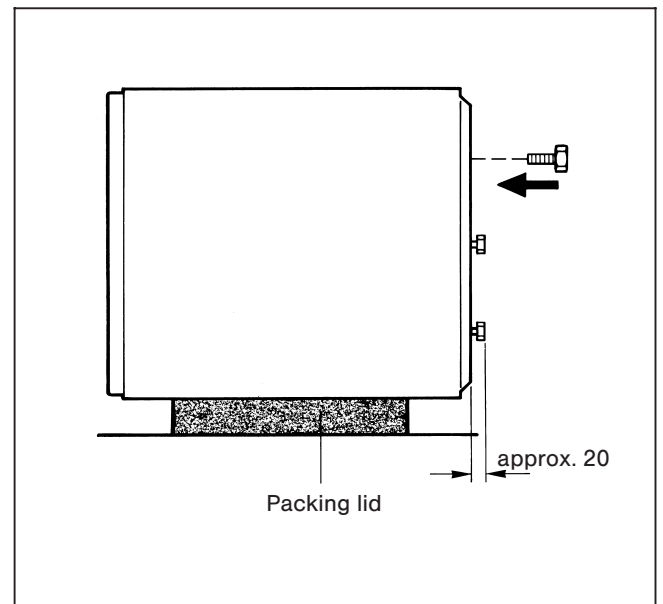

Fig. 3

## 5. Setting up

Choose a room with no risk of frost for the installation.

The calorifier must not freeze up and must be protected accordingly against frost or emptied.

The floor must be level and be able to support the load.

The minimal clearances according to Fig. 4 must be maintained.

### Note:

A = refer to the relevant Installation Instructions for the pipe connections for clearances (Fig. 4).

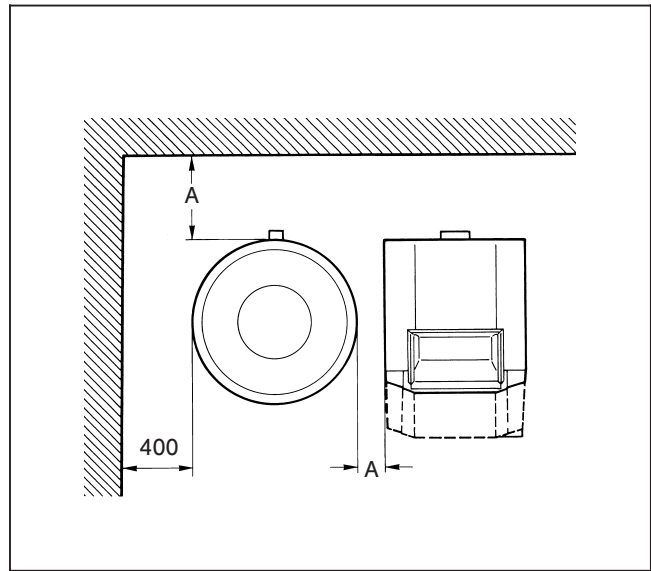

Fig. 4

## 6. Fitting

### Note:

Refer to the relevant Installation Instructions for accessories such as the calorifier-boiler pipe connection.

- Adjust the screw-on feet to align the domestic hot water storage calorifier in a vertical position (Fig. 5).

### Installation

Water circuits installation and equipment according to DIN 1988 and DIN 4753 (Fig. 6).

Position air vent and purge valve in the domestic water circuit in front of the shut-off valve.

Do not install any bends in the draining circuit to ensure desludging.

Attach an information label with the following text to the relief valve: "Do not close the blow-off pipe. For safety reasons, water can emerge during heating."

The blow-off pipe must have at least the same cross section as the relief valve outlet.

Activate the relief valve regularly to check the operation.

Call a qualified technician when the safety temperature limit stat triggers regularly.

- Check all connections for leakage !

All pipes and connections must be free from tension !

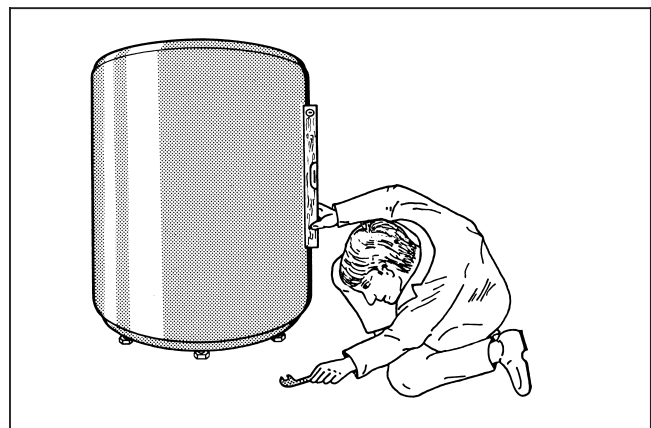

Fig. 5

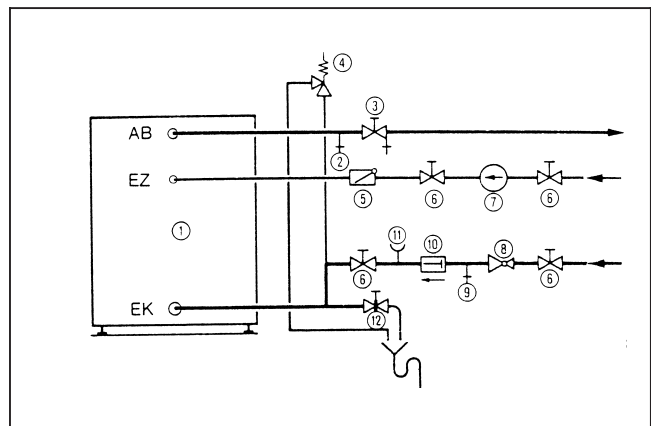

Fig. 6

### Legend:

- |                                      |   |
|--------------------------------------|---|
| 1 Storage tank                       | 7 Circulation pump                              |
| 2 Air vent and purge valve           | 8 Pressure reduction valve (when necessary)     |
| 3 Shut-off valve with drainage valve | 9 Testing valve                                 |
| 4 Relief valve                       | 10 Check valve                                  |
| 5 Shut-off valve                     | 11 Manometer connection unions (when necessary) |
| 6 Shut-off valve                     | 12 Drainage                                     |

AB = Domestic water outlet

EK = Cold water inlet

EZ = Circulation inlet

### Protection limits

Heating water temperature . . . . max. 160°C  
 Operating pressure (heating water) max. 25 bar  
 Domestic water temperature . . . . max. 95°C  
 Operating pressure . . . . . max. 10 bar

### Relief valve

Connection diameter minimum	Nominal water capacity l	Max. heating output kW
<b>DN 15</b>	<b>up to 200</b>	<b>75</b>
DN 20	above 200 – 1000	150
DN 25	above 1000 – 5000	250

according to DIN 4753

### Fitting the sensor

- Insert the sensor into the immersion well (MB) on the rear side of the calorifier (Fig. 7).
  - The plastic spiral which holds the sensor together automatically moves back during insertion (Fig. 8).
- The equalising spring must be pushed between the sensors (Fig. 8) to ensure contact between the immersion well and the sensor surfaces which in turn ensures reliable temperature measurement.
- Push the sensor fastener onto the immersion well head from the side or the top (Fig. 8).

### Magnesium anode

- Check that the magnesium anode is fitted and the earth cable is connected (Fig.10).

### Ecomatic control panel 4000

- Connect the connector on the earth cable to the cable from the control panel (Fig. 9).
- The connector is not used on other control panels.

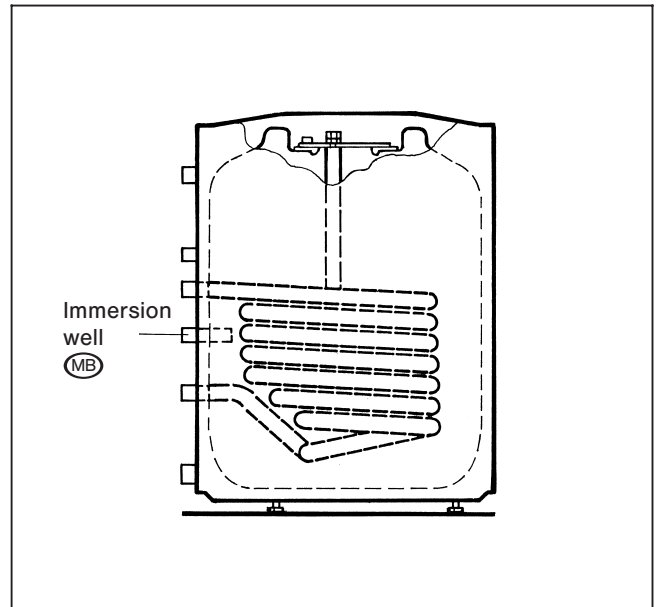

Fig. 7

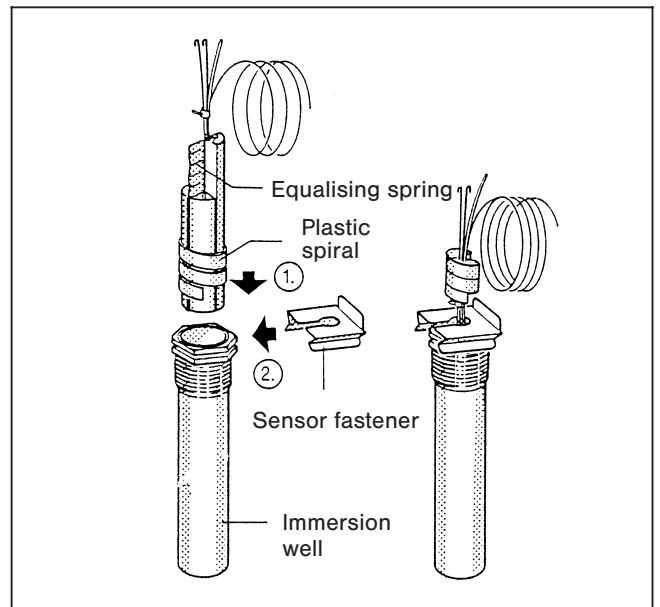

Fig. 8 – Schematic diagram

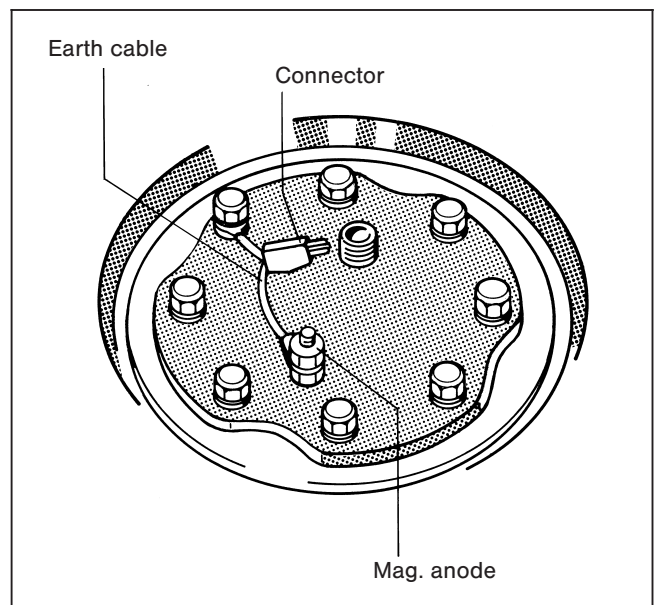

Fig. 9

## 7. Putting into operation

Check that the domestic hot water storage calorifier is filled with water and that the cold water inlet to the calorifier functions.

Check all connections and circuits for leakage.

The magnesium or inert \* anode must be connected so that it is operative.

Refer to the Operating Instructions of the control panel or the boiler (delivered with the control panel or boiler) for all necessary information on how to operate the domestic hot water storage calorifier.

The initial start-up should be carried out by the manufacturer or a competent heating technician recommended by the manufacturer, together with the person owning the unit.

\* = can be ordered as an accessory

## 8. Maintenance

Unless otherwise agreed in writing, the domestic hot water storage calorifier may only be filled with drinking water.

It is generally recommended to have the domestic hot water storage calorifier checked and cleaned by a heating technician at least every two years.

Shorter cleaning intervals are recommended for adverse water conditions (hard to very hard water) combined with high temperature output.

### Cleaning

Switch off the current before cleaning the unit.

- Shut-off the cold water flow and open the drain (EL). To air, open a tap positioned higher (Fig. 11).
- Unscrew the sheet metal screws from the side of the calorifier hood.
- Remove the calorifier hood.

#### Note:

Remove the anode connector with cable when an inert anode is fitted.  
Do not damage the anode.

- Ecomatic 4000 control panel: remove the connector on the earth cable (Fig. 10).
- Unscrew the hexagonal head screws from the handhole lid and remove the handhole lid with the magnesium anode (Fig. 10).
- Check and clean the storage tank.

**Warning:** Never use an object with a hard edge to chip off the coating because this can damage the inner panel surfaces.

- Check the magnesium anode and seal and replace the anode when it is down to 15 – 10 mm Ø, replace seal when necessary.
- Return the handhole lid, with magnesium anode and seal, into position.

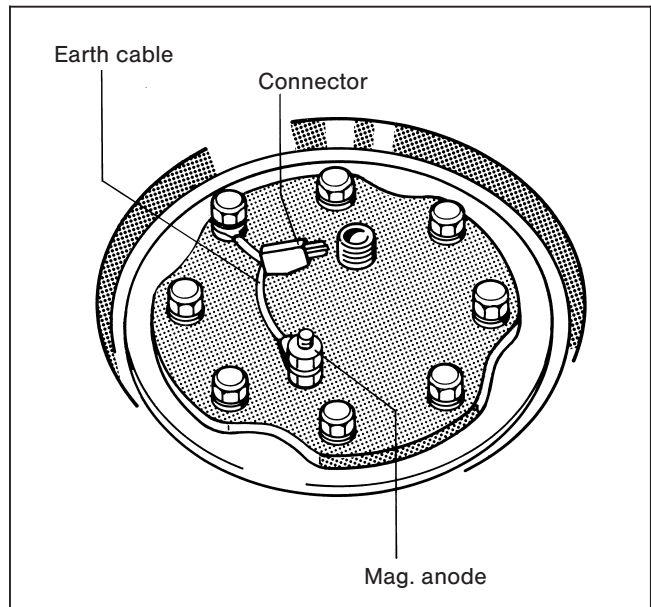

Fig. 10

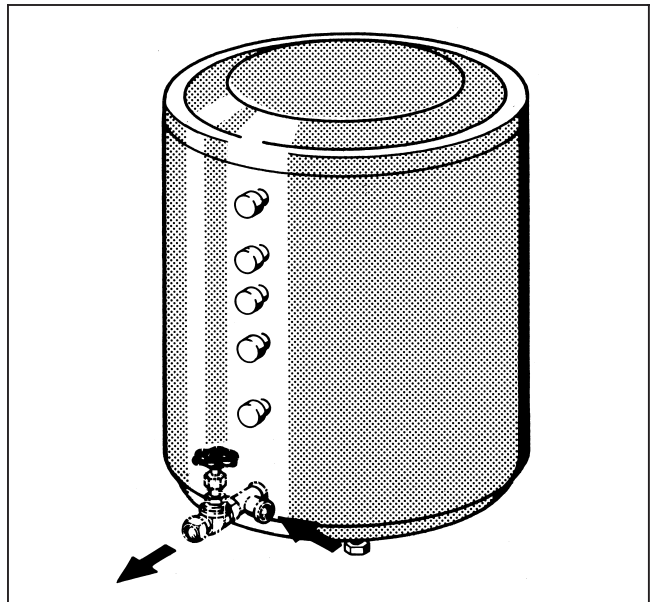

Fig. 11

- Attach the lug of the earth cable and screw the hexagonal head screws back on again (Fig. 10).

Ecomatic 4000 control panel: connect the connector on the earth cable back onto the cable from the control panel.

**Note:** Screw all the hexagonal head screws "finger tight" and then tighten them three quarters of a turn with a wrench (corresponds to the recommended torque 40 Nm with a torque wrench).

- Check the handhole lid for leakage.
- Position the thermal insulating disk in front of the handhole lid.
- Put the calorifier hood back on again and fasten it on the side with the 4 sheet metal screws.
- Put the unit back into operation.

### **Inert anode \***

A green signal lamp on the control panel (shock-proof plug) signals the protective function of the inert anode.

The signal lamp blinks red when a malfunction occurs (no corrosion protection).

Please inform the qualified heating company.

Avoid dirtying the anode with oil or grease.

\* = can be ordered as accessory

