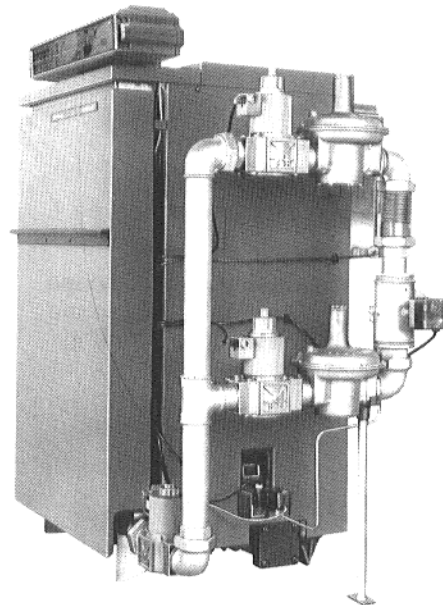


Installation instructions

Gas hot water boilers

GK 424 LZ LOWNOX and GE 424 LZ LOWNOX Ecomatic



Contents	page
1. Operating conditions	2
2. Connections and dimensions	3
3. Delivery	4
4. Installation	5
5. Assembly.	6 – 18
5.1 Tools and auxiliary materials	6
5.2 Assembling the boiler sections	6 – 7
5.3 Pressure test	8
5.4 Combustion chamber safety plates	9
5.5 Feed pipe	10 – 11
5.6 Rear boiler panel	12
5.7 Flue gas collector *	12 – 13
5.8 Boiler jacket	14 – 15
5.9 Burner grid	16
5.10 Fittings	17 – 18

	page
6. Electrical installations	19 – 22
6.1 General	19
6.2 Electrical connection and installation of control panel	19 – 21
6.3 Contact guard and pilot burner	22
7. Accessories	23 – 26
7.1 Valve leakage control	23
7.2 Flue gas blocking flap	24 – 25
7.3 Flue gas monitoring	26

Before installing, please read through the instructions very carefully.

1. Operating conditions

The Buderus gas hot water boiler G_424 LZ LOWNOX for burners without forced draught meets the requirements of gas device guideline 90/396/EEC in its design and operating behaviour.

Gas connection

The gas pipe may only be laid and connected by a licensed gas installer.

Instructions for the gas installer are included in the scope of delivery (see Instructions for putting into operation and maintenance for Buderus gas hot water boiler G_424).

Flue gas connection

The flue gas path should be chosen so that it is as short as possible. Flue gas pipe must be laid so that there is a slope to the chimney and must be connected tightly so that no condensed water can escape at the joints.

Thermally controlled flue gas blocking flaps must not be installed in the flue gas pipes.

Take note!

Operating conditions of boiler:

- max. boiler temperature: 120 °C
- max. operating pressure: 6 bar *)

*) The specifications on the rating plate are binding and must be observed!

- The maximum time delays T are for
- limitstat: 40 sec.
- thermostat: 40 sec.

If the boiler is not put into operation immediately after installation, the boiler and the burner must be covered up to protect them.

2. Connections and dimensions

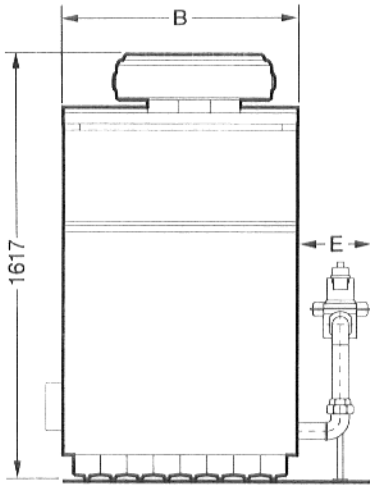


Fig. 1

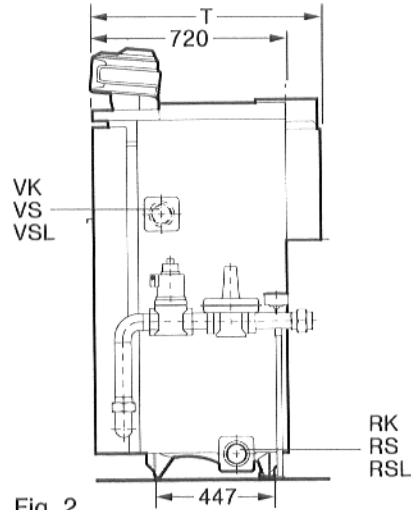


Fig. 2

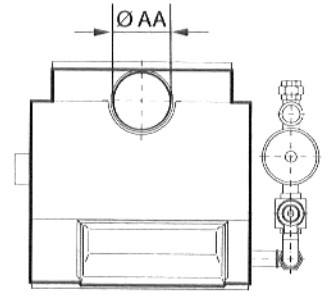


Fig. 3

gas connection Ø	E	F
1½"	285	375
2", 3"	350	440

Boiler connections

type	max. nominal value	designation of connection points
VK	80	boiler flow
RK	80	boiler return
VSL	80	safety flow circuit
RSL	80	safety return circuit
VS	50	calorifier flow
RS	50	calorifier return
EL	—	boiler drainage on site
Gas	—	gas connection

The water drag coefficient zeta (z) of the boiler is about 5.0.

Note

For safety reasons, the water connections (VK and RK) must not be interchanged, because a feed pipe has been fitted in the boiler return in the factory.

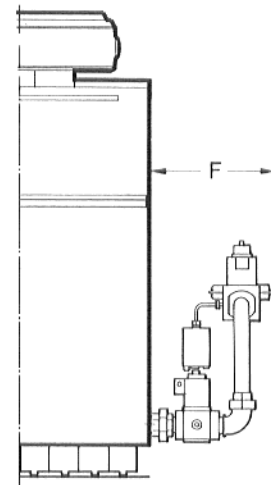


Fig. 1a

Version with valve leak control

Dimensions and technical data

boiler size type of construction	nominal heat load	nominal head output	boiler width B mm	boiler depth T mm	flue gas connection piece Ø AA mm	water capacity l	gas connection gas natural gas
	natural gas kW	natural gas kW					
105- 7	115.4	105	780	880	225	98	1½"
122- 8	133.9	122	880	880	225	112	1½"
140- 9	153.7	140	980	880	225	126	1½"
157-10	172.2	157	1080	880	225	140	1½"
175-11	191.7	175	1180	970	300	154	1½"
192-12	210.3	192	1280	970	300	168	2"
209-13	228.7	209	1380	970	300	182	2"
227-14	248.1	227	1480	970	300	196	2"
244-15	266.7	244	1580	970	300	210	2"
262-16	286.0	262	1680	970	360	224	2"
279-17	304.3	279	1780	970	360	238	2"
297-18	323.9	297	1880	970	360	252	2"
314-19	342.1	314	1980	1010	400	266	2"
331-20	360.6	331	2080	1010	400	280	2"
349-21	379.8	349	2180	1010	400	294	2"
366-22	397.8	366	2280	1010	400	308	2"

3. Delivery

The Buderus hot water boiler G_424 is assembled in boiler sizes from 105-7 up to 175-11 and delivered in loose sections in the boiler sizes from 192-12 up to 366-22.

If desired, boiler sizes 105-7 up to 175-11 can also be delivered in loose sections.

a) boiler block assembled (Fig. 4)

- 1 boiler block
- 1 carton boiler jacket
- 1 crate with flue gas collector, feed pipe, burner grid and flue gas blocking flap with drive motor (accessory)
- 1 carton burner fittings for ionic monitoring
- 1 carton burner control
- 1 carton control panel

* Accessories packed separately and ordered separately.

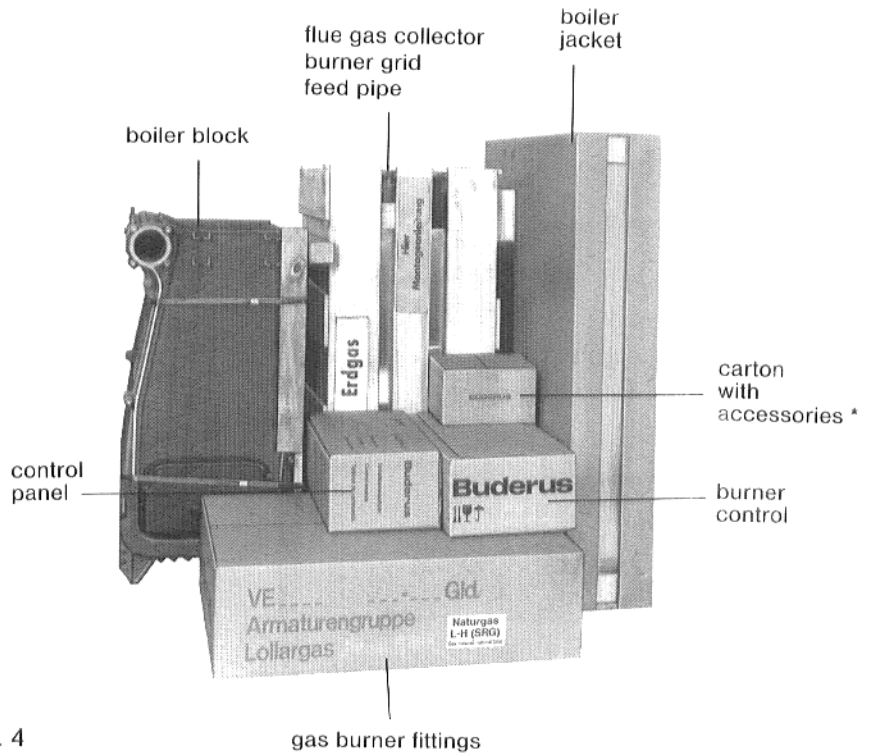


Fig. 4

b) boiler in loose section (Fig. 5)

- 1 right-hand end section
- 1 left-hand end section middle sections
- 1 carton nipples, boiler putty, red lead oxide putty and combustion chamber safety plates
- 1 bundle tie bars (2 items)
- 1 carton boiler jacket
- 1 crate with flue gas collector, feed pipe, burner grid and flue gas blocking flap with drive motor (accessory)
- 1 carton gas burner fittings for ionic monitoring
- 1 carton burner control
- 1 carton control panel

* Accessories packed separately and ordered separately.

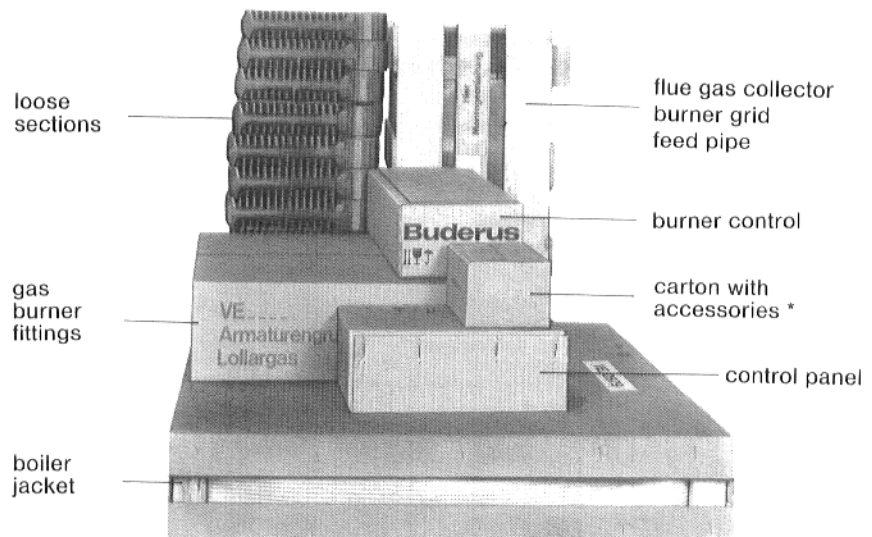


Fig. 5

4. Installation

It is recommended that the boiler be mounted on a concrete or brick foundation about 5 – 7 cm high. The foundation must be made to match the boiler depth (720 mm) and width (measurement B) of the boiler with jacket and should be completely flat and horizontal (Fig. 6).

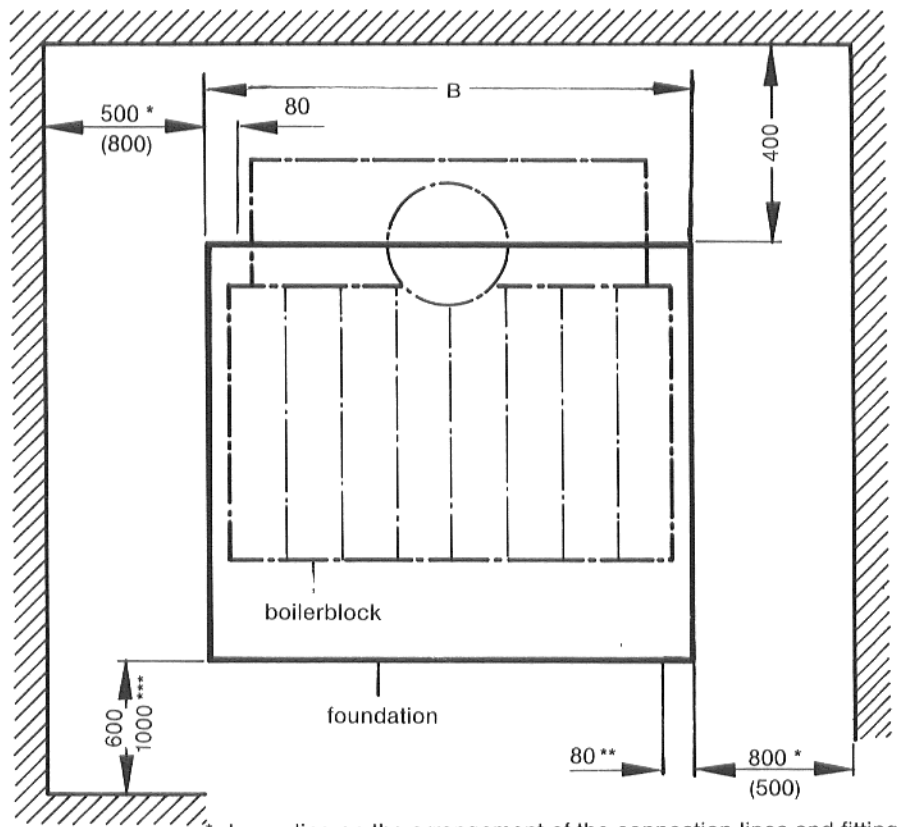


Fig. 6

* depending on the arrangement of the connection lines and fittings
 ** heat insulation
 *** if there is a stationary separating wall in front of the boiler

boiler size / type of construction	105-7	122-8	140-9	157-10	175-11	192-12	209-13	227-14
boiler width / foundation (measurement B)	780	880	980	1080	1180	1280	1380	1480

boiler size / type of construction	244-15	262-16	279-17	297-18	314-19	331-20	349-21	366-22
boiler width / foundation (measurement B)	1580	1680	1780	1880	1980	2080	2180	2280

When assembling the boiler, on the left and right next to the boiler, the specified distances from the walls must be provided without fail for servicing and repair work (see Fig. 6).

Any deviations in the specifications in individual countries or counties must be taken into account.

Align the boiler block vertically with a spirit gauge on the sealing strips and, if necessary, push metal wedges or sheet metal strips underneath.

Every third section at least must be supported so that it stands firmly.

The water connections can be made on the left or right, depending on local conditions, but must be made only on **one side** of the boiler.

The gas burner fittings should be fitted to match local conditions (optionally on the right or the left of the boiler).

The servo-motor for the flue gas blocking flap can only be installed on the right.

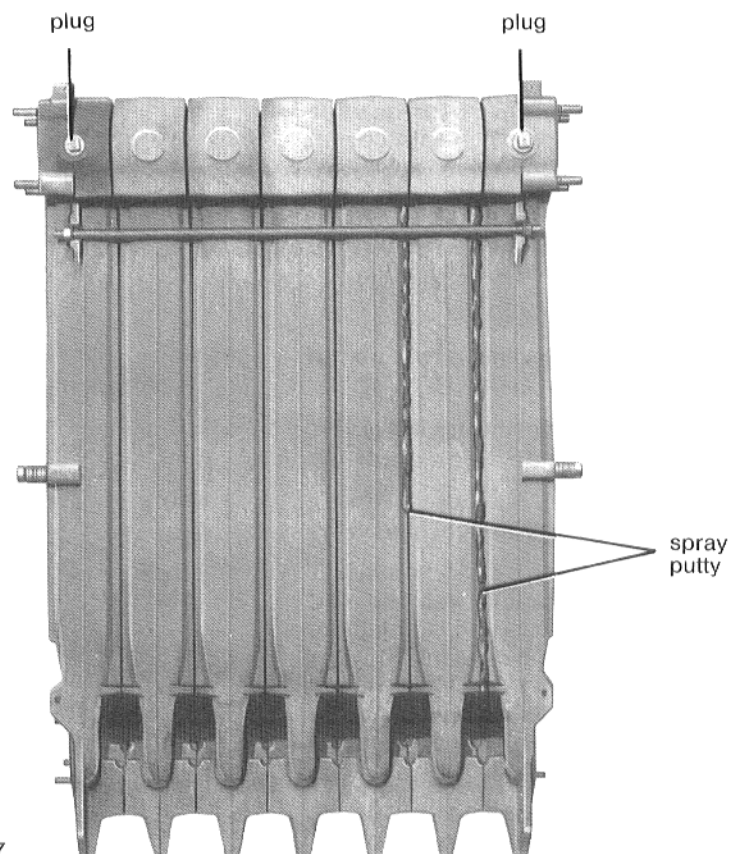


Fig. 7

5. Assembly

5.1 Tools and auxiliary materials

For assembling, the following tools and auxiliary materials are required:

1. complete pressing tool if delivered in loose sections (bar pressing tool)
2. steel hammer and wooden or rubber mallet
3. half-round bastard file
4. screwdriver
5. flat chisel
6. socket wrenches SW 17, 19, 24
7. angular socket wrenches SW 17, 19
8. linseed oil red lead oxide putty (viscous)
9. boiler putty (spray putty); if too firm, thin with sodium water glass, not with water
10. graphite paste (for lubricating the bolts and nuts)
11. spray bag
12. cleaning wool
13. fine coated abrasives
14. solvent (naphtha)
15. brush

Linseed oil red lead oxide putty and boiler putty are provided in sufficient quantities in the scope of delivery.

Caution!

For mounting the pilot burner with ionization monitoring, use the socket wrench (SW 7) supplied. The key is packed together with the pilot burner.

5.2 Assembling the boiler sections

If delivery is made in loose sections, the boiler is pressed together with a bar pressing tool. If space is lacking, the pressing tool can be put together from smaller pieces.

Before assembling, clean the boiler bosses and nipples with a cloth soaked in naphtha, check for damage and, if necessary, clean with coated abrasive and deburr with a bastard file.

Coat nipples and bosses equally with linseed oil red lead oxide putty.

Caution!

Before coating, the linseed oil must be tipped off.

Correct insertion of the nipples is very important for perfect sealing of the nipple connections.

The nipple must sit straight and on the axis of the boss.

Insert nipple, starting with the end section, in the boss with light taps of the wooden or rubber mallet. The taps with the mallet must always be made on the inside edge, not on the outside edge of the nipples, since otherwise they will be damaged.

If a burr arises by tapping on a nipple, it must be deburred without fail.

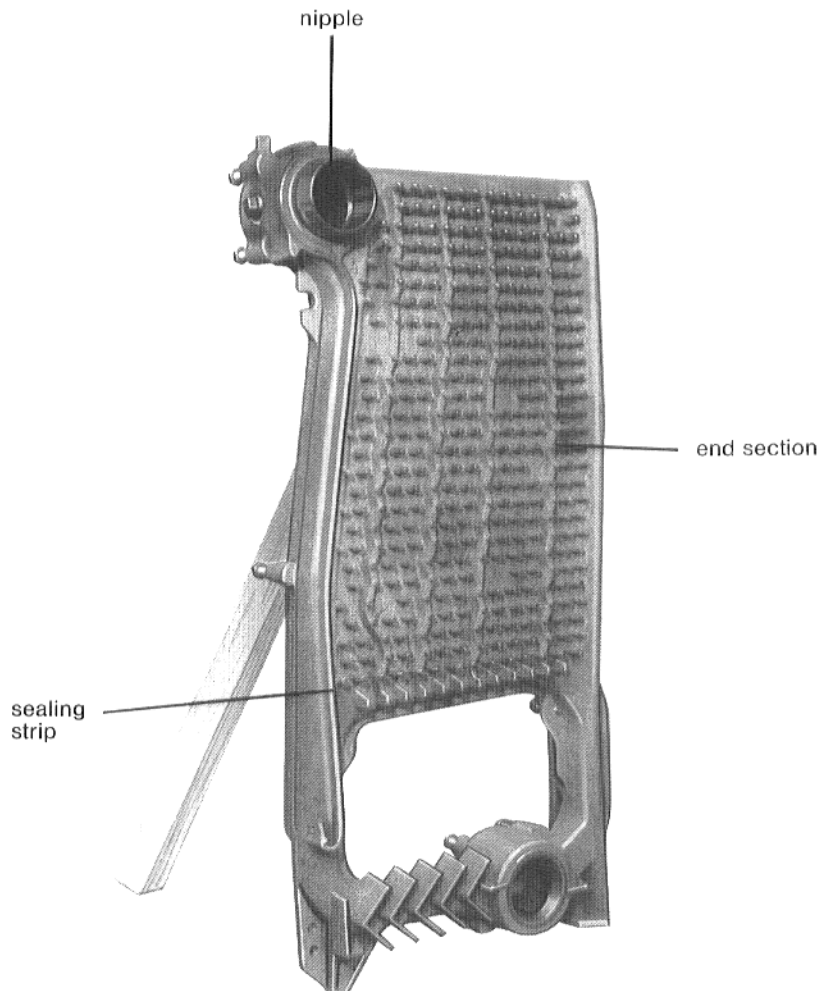


Fig. 8

Erect the **right-hand or left-hand end section** at the point where it will stand. Put the next (middle) section with bosses onto the nipples.

Insert bar pressing tool in the upper and lower bosses.

If a bar pressing tool in sections is used, the bolt connections must be secured by wrapping insulation tape around them.

Press both sections together simultaneously.

Never assemble more than two sections at a time.

If the sealing strips abut, the sections must not be pressed together by force under any circumstances (Figs. 8 and 9).

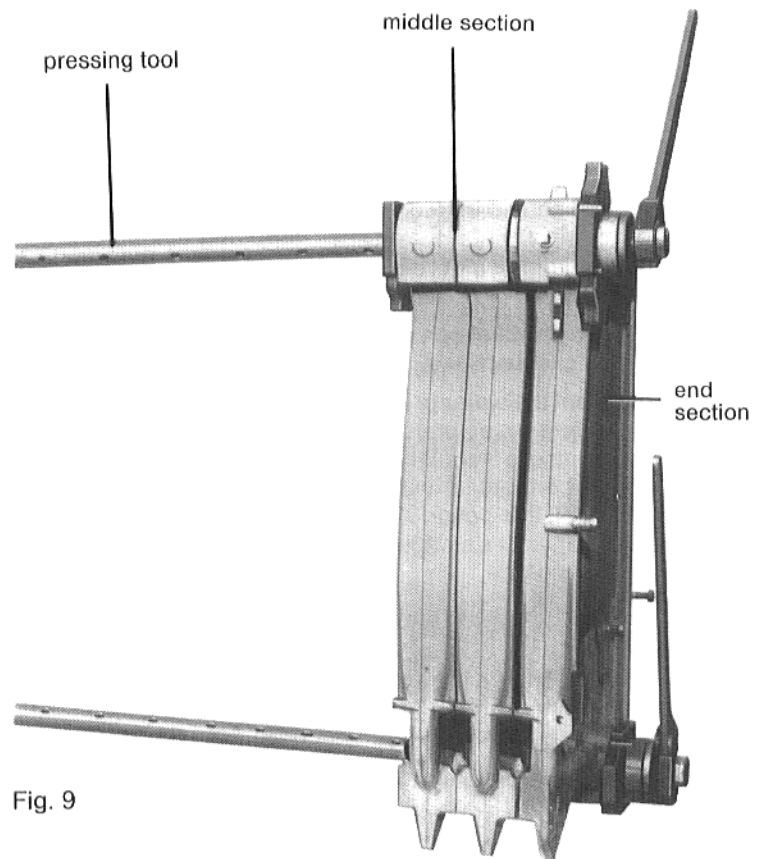


Fig. 9

After pressing together the boiler block, loosen the pressing tool, but do not take it out yet.

Insert **tie bars** front top and rear bottom with the **spring washers** in the slots provided. Tighten the nuts finger-tight and then tighten a quarter turn with a wrench (Figs. 10 and 11).

Remove pressing tool.

detail "A"

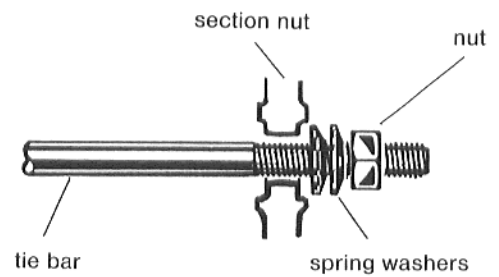


Fig. 10

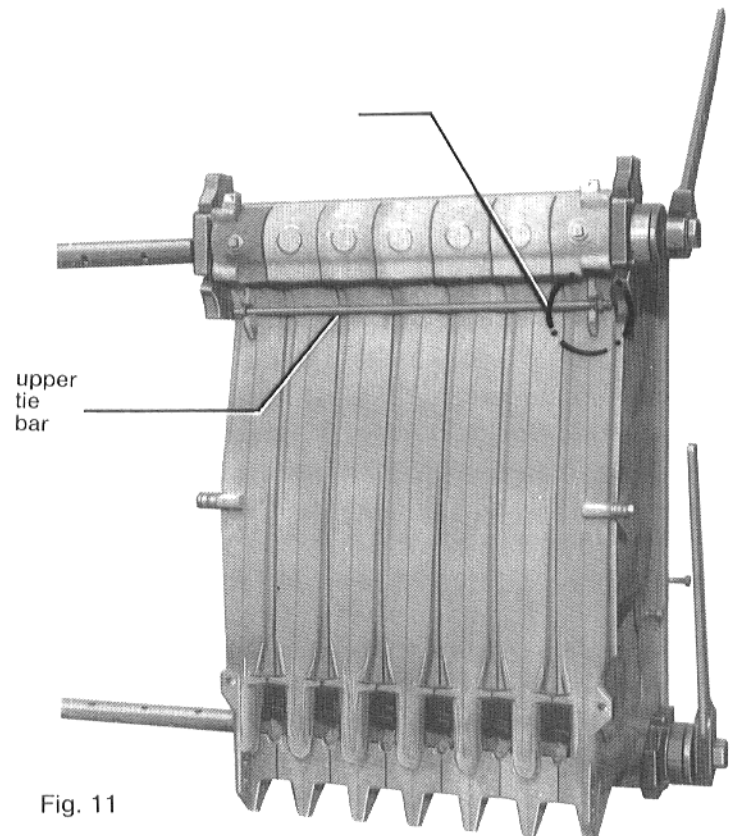


Fig. 11

5.3 Pressure test

Before performing further work, a water pressure test must now be made on the boiler block.

Before the pressure test, the pocket sensors must be sealed in (Fig. 12). If devices from other manufacturers are fitted, the pocket sensor must be positioned on site.

Always seal in the pocket sensors on the front of the end sections.

When carrying out the water pressure test or leakage test resp., there must not be any pressure regulation or safety devices connected with the water chamber of the boiler. Otherwise there is danger of damage caused by excess pressure.

Filling the boiler

Caution! Fill only slowly from **below** through the filling and drainage tap.

Purging air from the boiler

During filling, purge air at the **highest point where water flows** until water comes out.

Every boiler that is assembled on site must be subjected to the water pressure test by the installing contractor with the following test pressures:

p_1 is the permissible operating pressure specified on the rating plate.

A certificate must be issued about the water pressure test. The installation owner needs this to obtain an operating license.

Leakage test

A leakage test must be carried out. The test pressure depends on the pressure prevailing in the heating installation and in 1.3 times this pressure and at least 1 bar.

For measuring the pressure, a pressure gauge of the class 1.0 must be used.

If the boiler has a leak at a boss connection, remove the tie bars and separate the boiler at that point. To do this, drive in a chisel in the area around the leaky boss on the humps.

Before reassembling, clean the bosses and use new nipples. Reinsert the tie bars and repeat the pressure test.

After the pressure test, seal the boiler with spray putty (spray bag) and coat evenly in the joint with the brush (Fig. 12). Connect the water pipes. **Take account of space requirements for the gas burner (fittings)** (see 4. Installation).

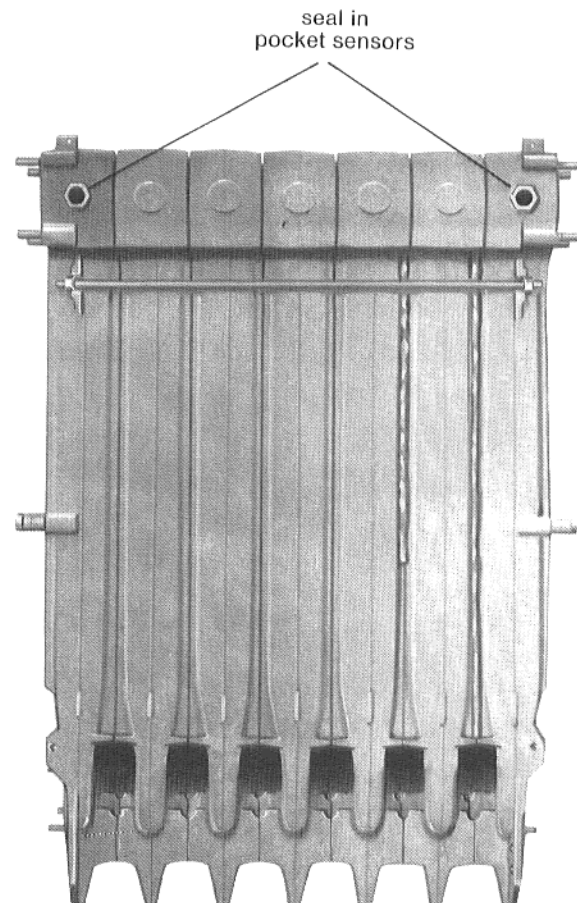


Fig. 12

5.4 Combustion chamber safety plates

Before fitting the boiler jacket, the combustion chamber safety plates on the side must be installed.

Combustion chamber side plate "A" (with inspection port) for installing the pilot burner must be fitted where the gas burner fittings are installed.

The inspection port flap is only fitted after the pilot burner has been assembled.

Figures 13 and 13a show the state of combustion chamber safety plate A on delivery.

If town gas is used, the upper stud bolt must be removed, the pilot burner flange must be replaced and must only be fastened with the hexagonal head bolt below (Fig. 13b). Pilot burner AZ7 for natural and liquid gas and pilot burner ZAi for town gas.

Position the combustion chamber safety plate on the end section and screw on left and right with washer and nut.

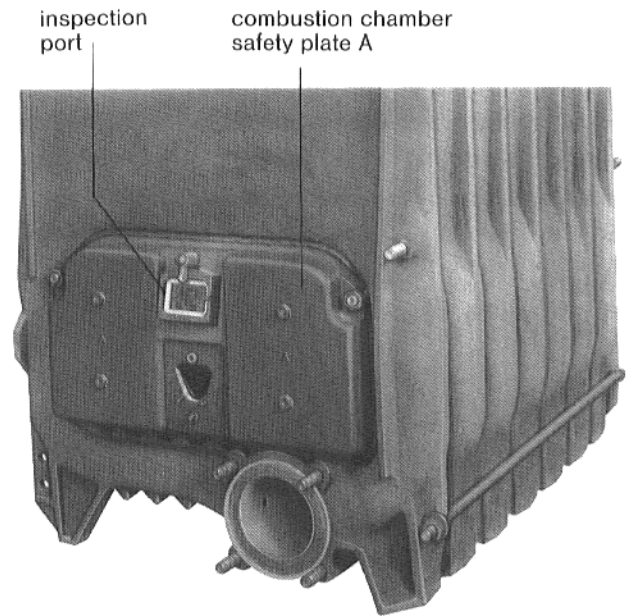


Fig. 13 – Schematic illustration

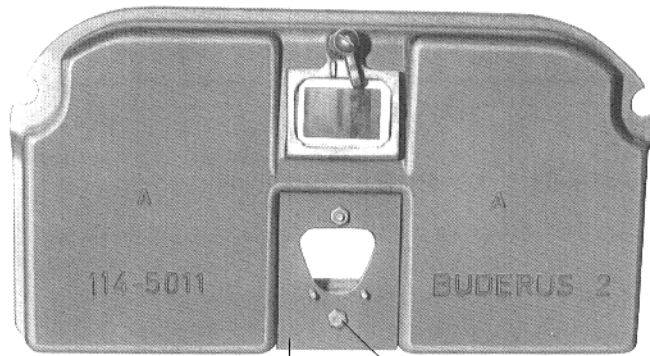


Fig. 13 a pilot burner flange hexagonal head bolt

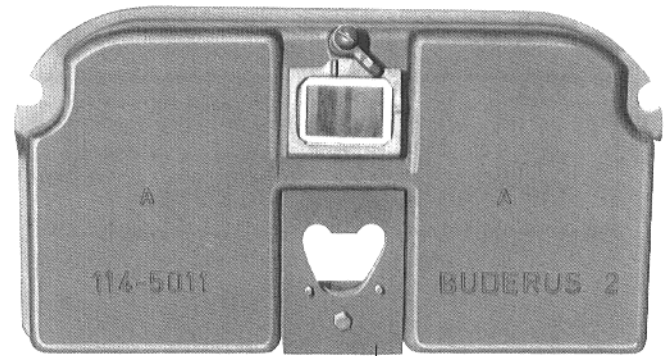


Fig. 13 b pilot burner flange

Combustion chamber side plate "B" must be fitted on the opposite side of the boiler (Fig. 14).

The monitoring electrode must be screwed in after installing the pilot burner.

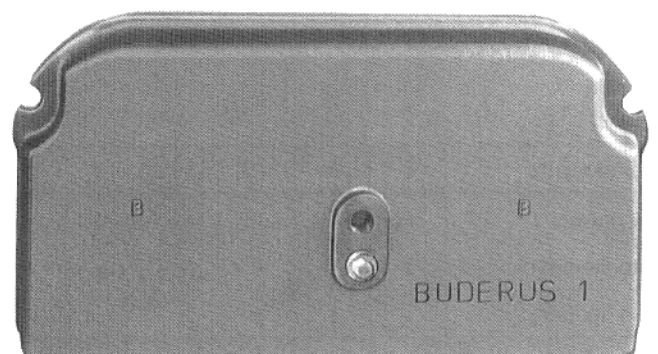


Fig. 14

5.5 Feed pipe

Before installing the boiler flow and the boiler return, the feed pipe must be fitted in the lower boiler boss (boiler return).

Parts for the feed pipe are packed with the draught hood.

Heating flow as well as heating return must always be connected to one side (Fig. 17).

The feed pipe consists of two end pieces (item 1) and, depending on the boiler size, one or several middle sections (item 2, 3 or 4) as well as connecting parts (item 5) see Fig. 15 and table).

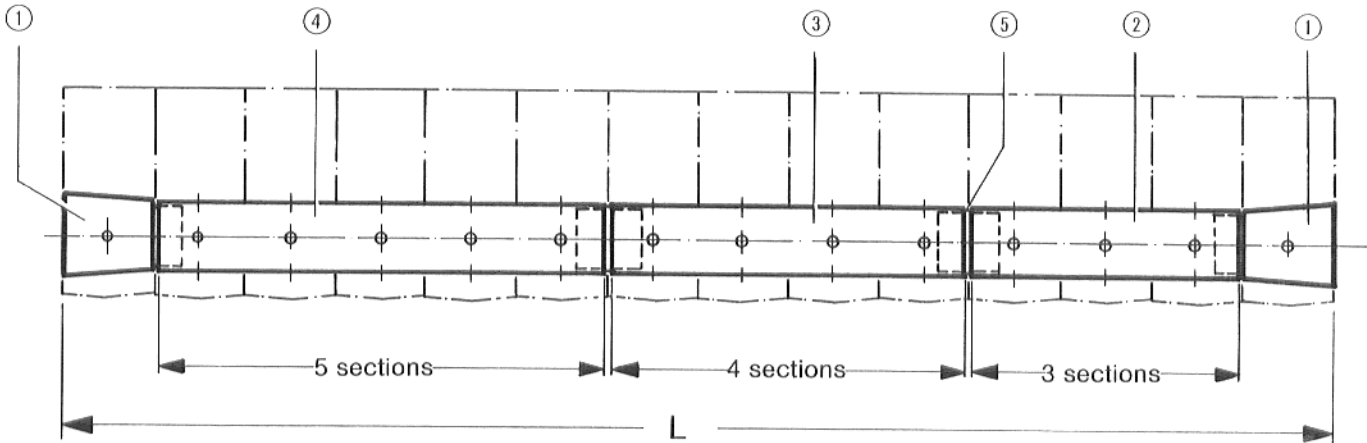


Fig. 15

- item ① end part
- item ② middle part for 3 sections
- item ③ middle part for 4 sections
- item ④ middle part for 5 sections
- item ⑤ connecting part

Table:

no. of sects.	7	8	9	10	11	12	13	14	15	16	17	18	19	20	21	22
measur. L	700	800	900	1000	1100	1200	1300	1400	1500	1600	1700	1800	1900	2000	2100	2200
no. item 2	-	2	1	-	-	-	1	-	1	-	-	-	-	1	-	-
no. item 3	-	-	1	2	1	-	2	3	-	1	-	4	3	-	1	-
no. item 4	1	-	-	-	1	2	-	-	2	2	3	-	1	3	3	4
no. item 5	-	1	1	1	1	1	2	2	2	2	2	3	3	3	3	3

Assembly sequence:

1. Put together middle part (item 2, 3 or 4) depending on boiler size and connecting part (item 5) (Figs. 15 and 16).

For boiler size 105 – 7 no connecting part (item 5) is necessary.

2. Stick the first end part (item 1) in the last middle part of the feed pipe (items 2, 3 or 4) and push into the lower boiler boss up to stop (Fig. 16).

3. Push return connection flange with a seal onto the lower boiler boss and screw on loosely (Figs. 16 and 17).

4. Push the second end part (item 1) on the opposite side of the boiler in the lower boiler boss onto the middle part (item 2, 3 or 4) (Fig. 17).

5. Put a blind flange with seal onto the lower boiler boss and screw on (Fig. 17).

6. Connect the boiler water in line with the local building codes.

– **The connecting pipes must be laid and connected to the boiler without any strain.**

– **Take account of space requirements for the gas burner (fittings).**

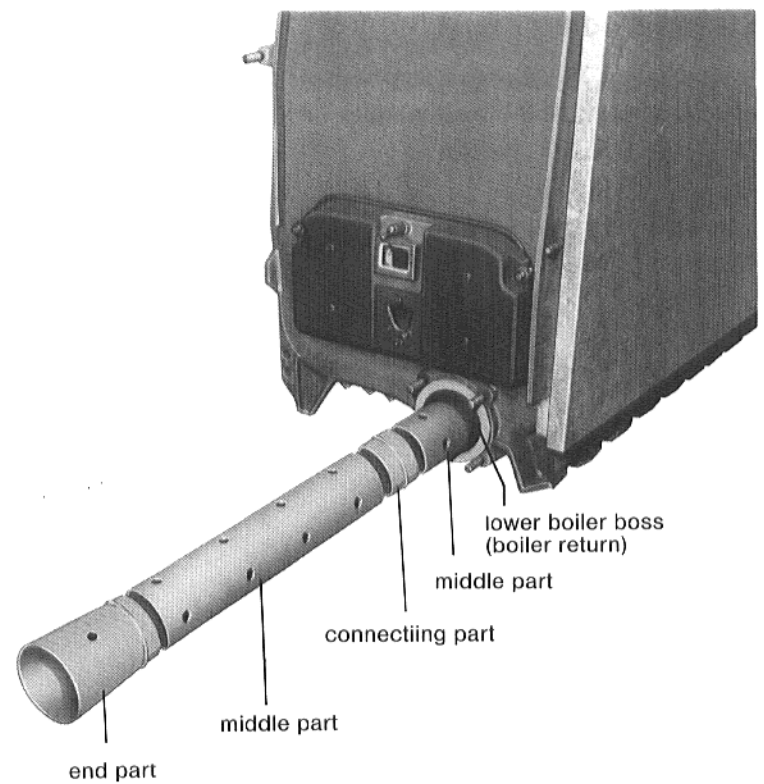


Fig. 16 – Schematic illustration

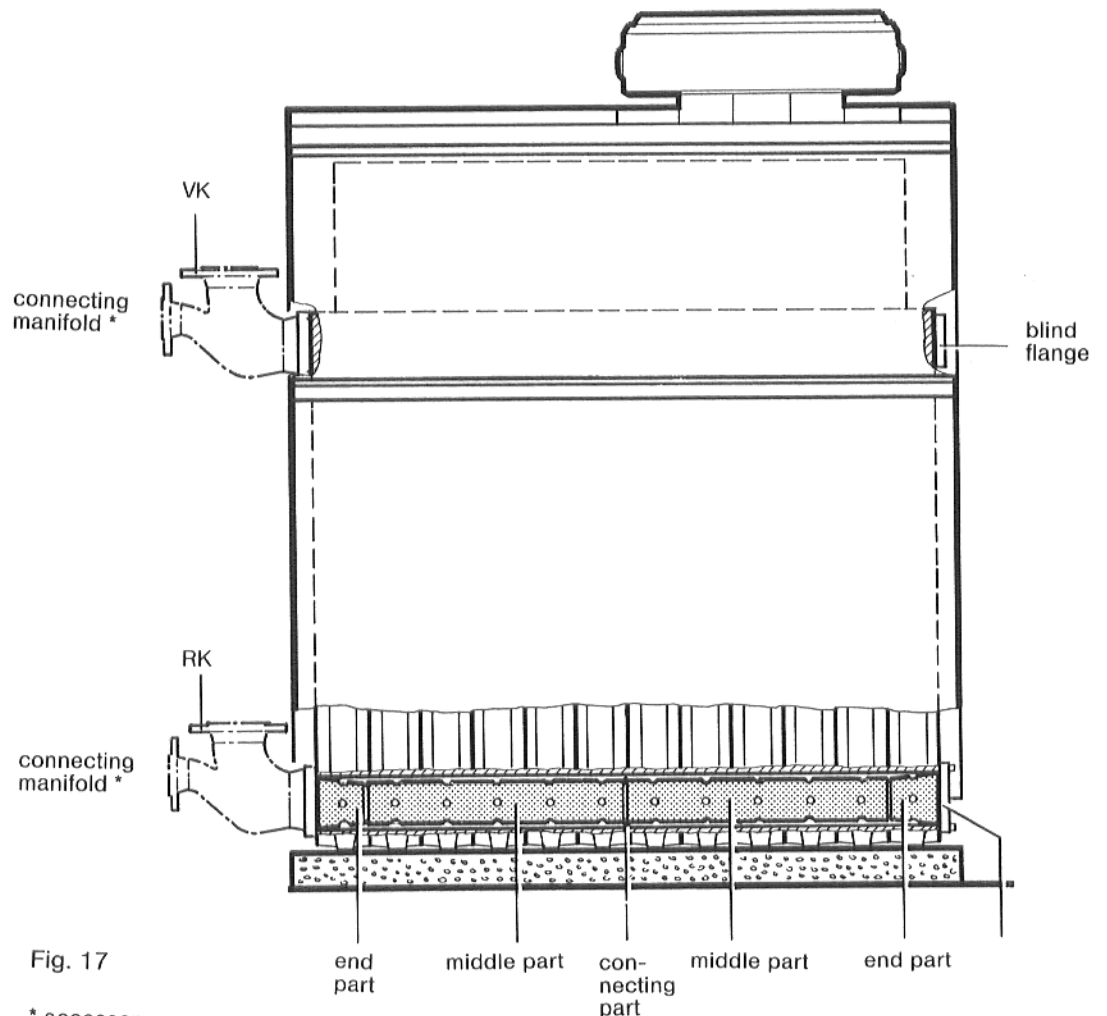


Fig. 17

* accessory

5.6 Rear boiler panel

Mount the **rear boiler panel** on the stud bolts of the end sections (Fig. 18).

Put the washers supplied onto the stud bolts and screw on nuts (see Fig. 18).

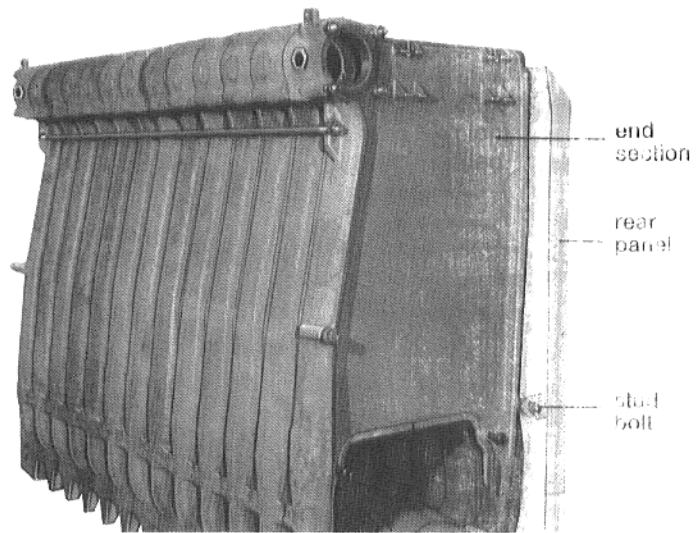


Fig. 18

5.7 Flue gas collector

Lay **sealing cord** for the front side of the flue gas collector on the boiler block (Fig. 19).

The sealing cord for the side parts is placed in the flue gas collector for delivery.

Caution!

If a flue gas blocking flap is supplied, it must be installed before assembling the flue gas collector (see 7.2 Installing the flue gas blocking flap).

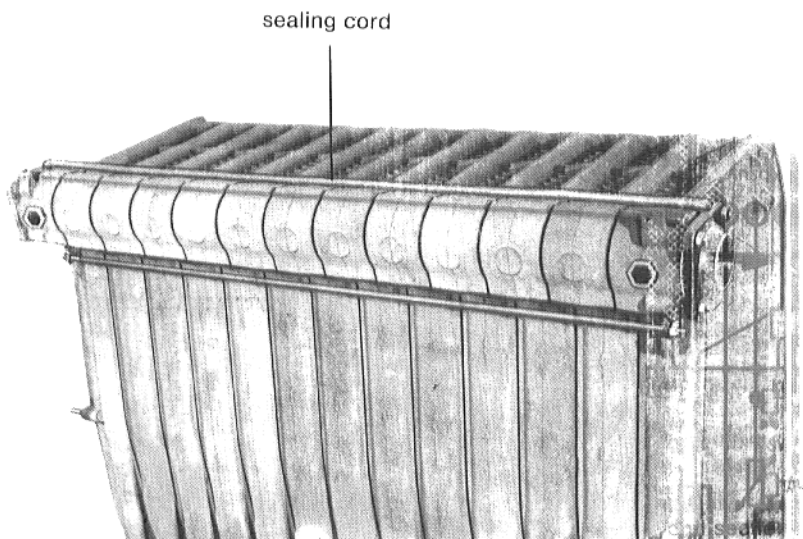


Fig. 19

Insert **cleaning cover** in the flue gas collector (Fig. 21).

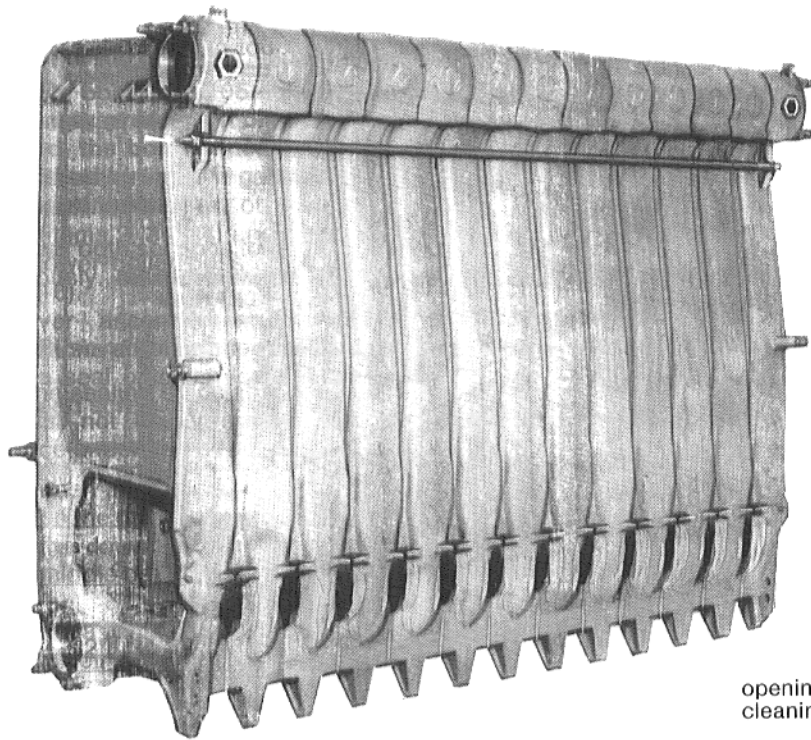


Fig. 20

Place flue gas collector on the boiler and screw it together loosely with the boiler. **Press in the flue gas collector on the rear (see arrow),** then tighten the flue gas collector (Fig. 23).

Fasten the **flue gas collector** from the front with the tension bracket as follows: insert **tension pieces** (Fig. 22).

Arrange the outer tension bracket in such a way that it has an effect at the end of the bracket bar and makes contact in the middle of the round outer surface of the section (Fig. 23).

For boiler sizes 105-7 up to 279-17, 2 tension brackets are supplied.

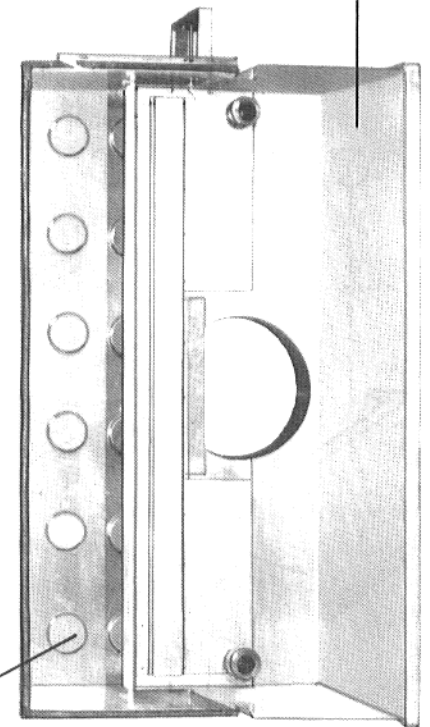
For boiler sizes 297-18 up to 366-22, 3 tension brackets are supplied.

The third tension bracket is fitted in the middle.

Laterally, the flue gas collector must be screwed on with two fastening bolts and seal up with boiler putty.

Tighten tension bracket (Fig. 22).

flue gas collector



opening for cleaning cover

Fig. 21 - Schematic illustration

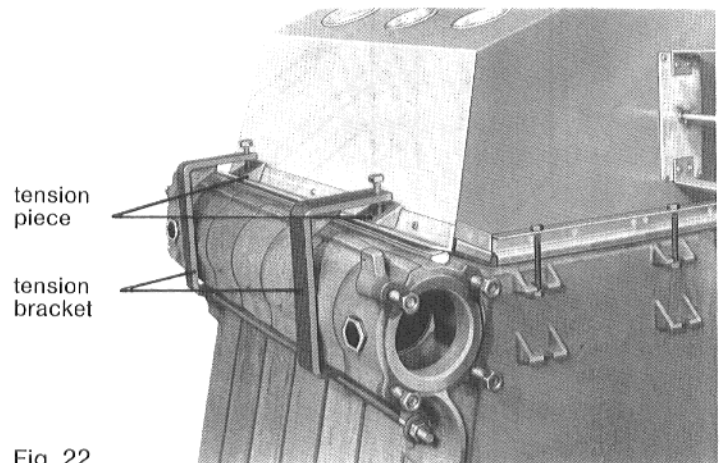


Fig. 22

lateral fastening screws with nuts and washers

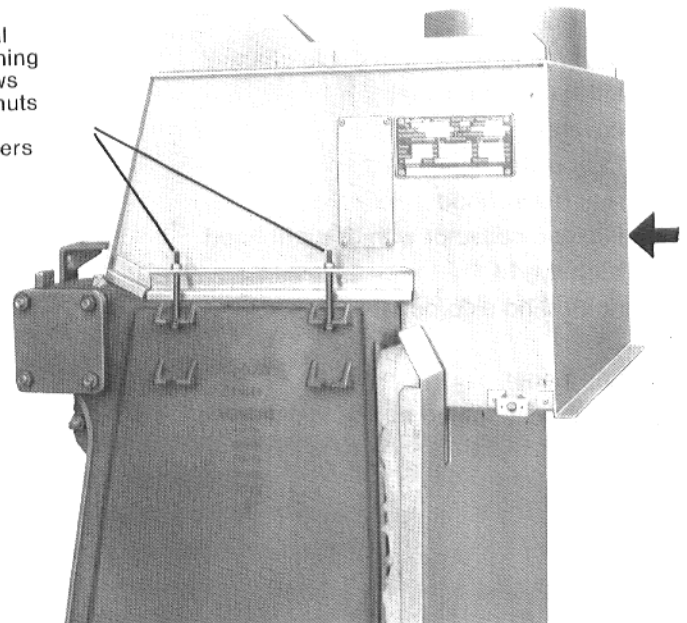


Fig. 23

5.8 Boiler jacket

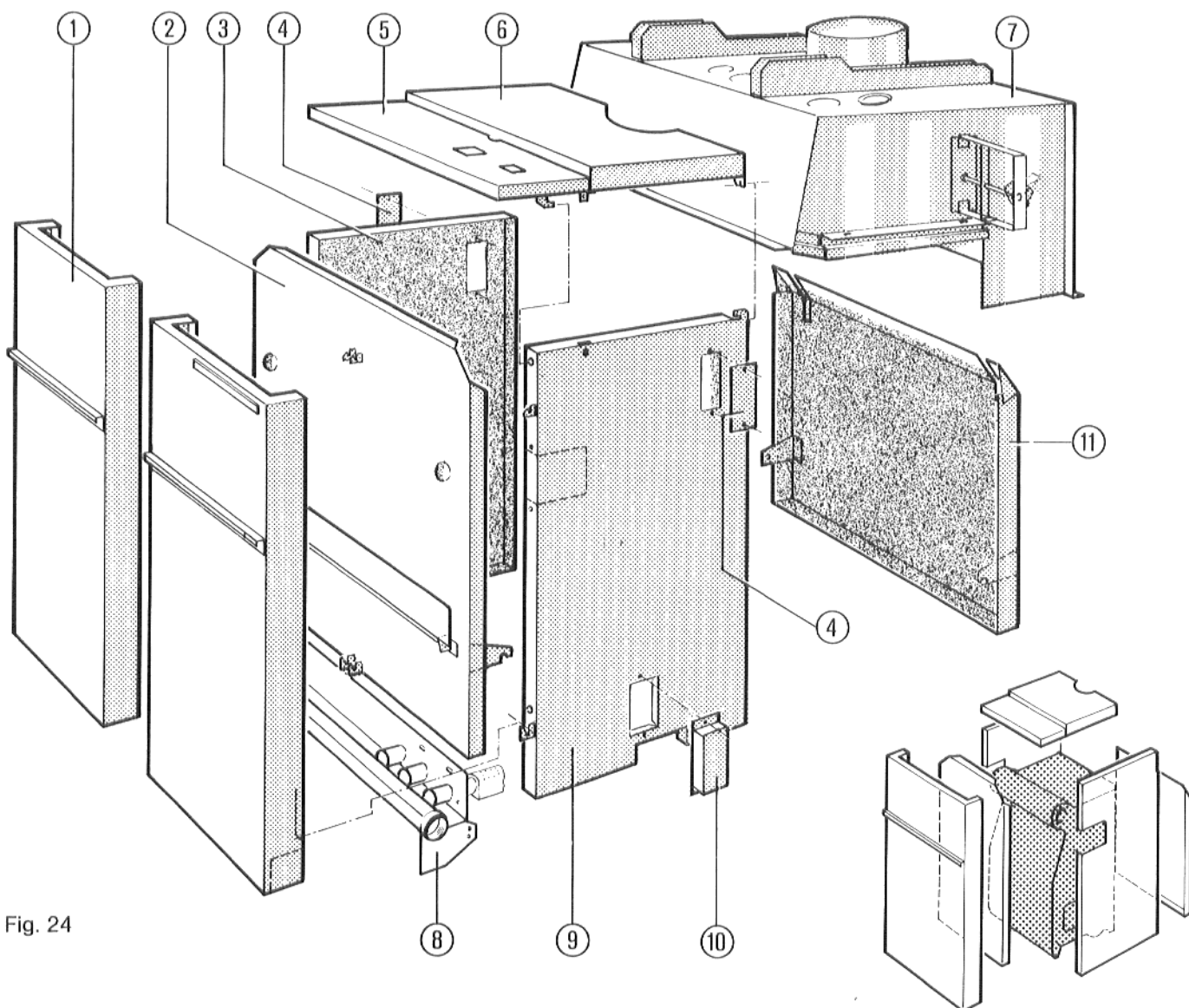


Fig. 24

Parts

- ① front panel
- ② separating panel with cable channel
- ③ left-hand side panel
- ④ covering panel
- ⑤ front boiler hood
- ⑥ rear boiler hood
- ⑦ flue gas collector with draught hood
- ⑧ burner grid
- ⑨ right-hand side panel
- ⑩ cover
- ⑪ rear panel
- ⑫ rating plate (fitted during installation)

Mount the **separating panel** on or in the stud bolts of the end sections (Figs. 18 and 25).

Place the washers supplied on the stud bolts and screw on the nuts.

Lay the overhang of the heat insulation blanket on the draught hood (Fig. 25).

Screw the **separating panel** loosely onto the end sections with bolts M8 x 65 and washers (Fig. 25).

Break out the **break-out parts** from the side panels at the intended flow and return connections.

Caution!

When equipping with a flue gas blocking flap, it must be fitted before fitting the right-hand side panel (see 7.2 Flue gas blocking flap).

Fit the **side panels** from the front from the side on the separating panel and screw onto the rear panel and separating panel with self-tapping screws (Fig. 26).

Tighten M 8 bolts of the separating panel fastener after aligning the side panels (Fig. 25).

Push the **front boiler hood** with the two hooks on the right and left into the bores of the bevelled edge of the side panel. Push the two rear lateral flaps into the appropriate slots in the upper side panel bevelled edge and fasten in the bores in the side panels with self-tapping screws.

The **front panel** and the **rear boiler hood** are fitted after the control panel is assembled.

It must be kept in mind that the rating plate accompanying the technical documents has to be mounted on the front panel (if there are two front panels, on the right-hand panel) (Fig. 24).

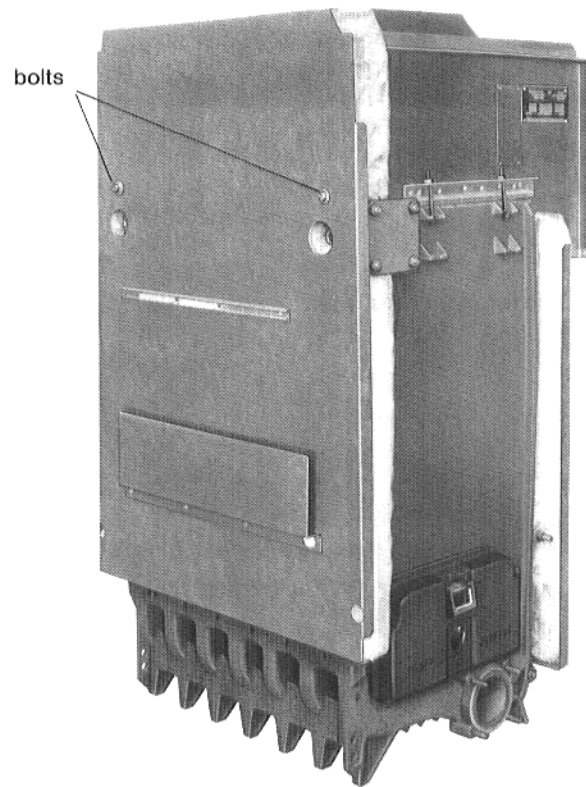


Fig. 25

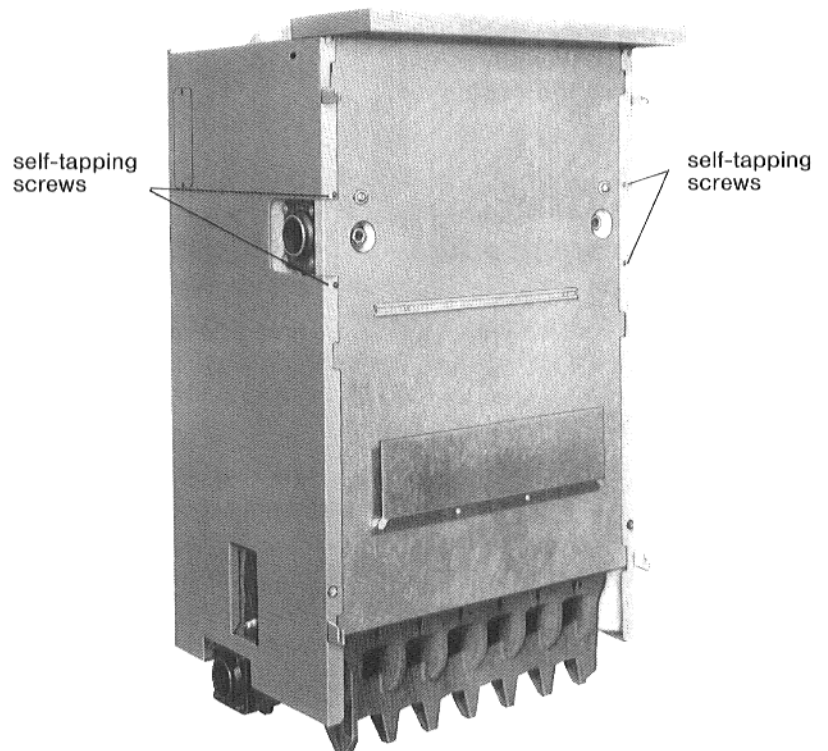


Fig. 26

5.9 Burner grid

Push the **burner grid** into the boiler. Screw the corbels of the burner grid from the inside loosely with M 12x30 bolts and nuts and washers together with the section feet of the end sections (Figs. 27 and 28).

Caution!

Plugs on the burner grid are not sealed in.

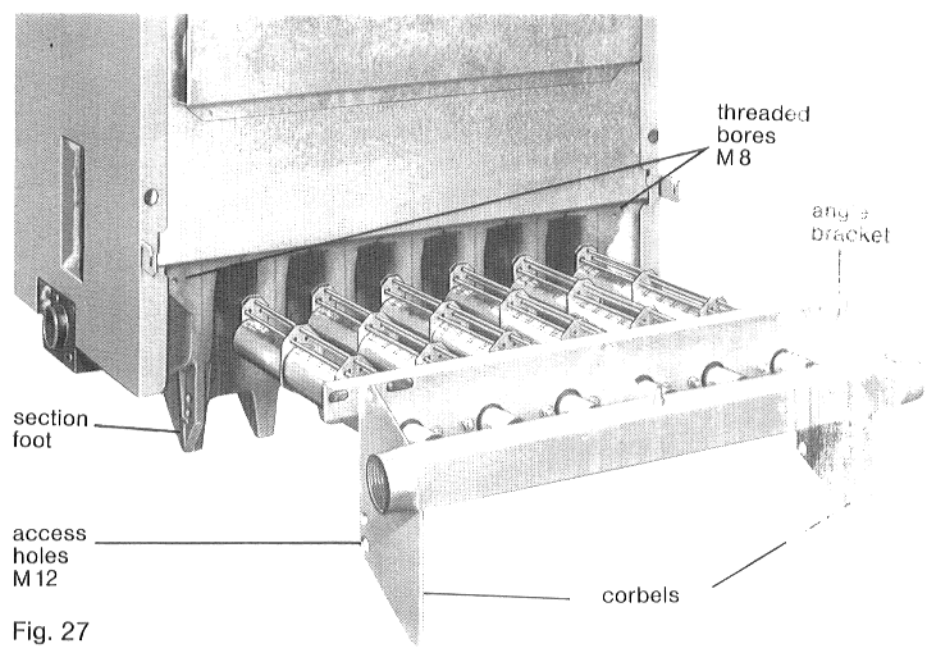


Fig. 27

Position of cooling rods

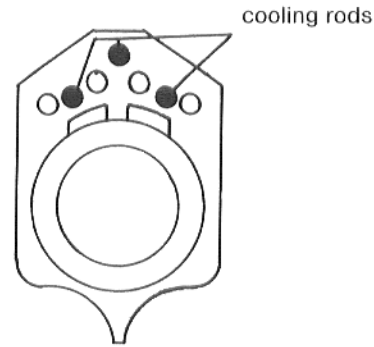


Fig. 27 a - Detail "A"

Screw the burner grid with angle bracket and fastening bolts M 8 x 30 and washers onto the end sections of the boiler. After that, screw the corbels together tightly with the section feet (Fig. 28).

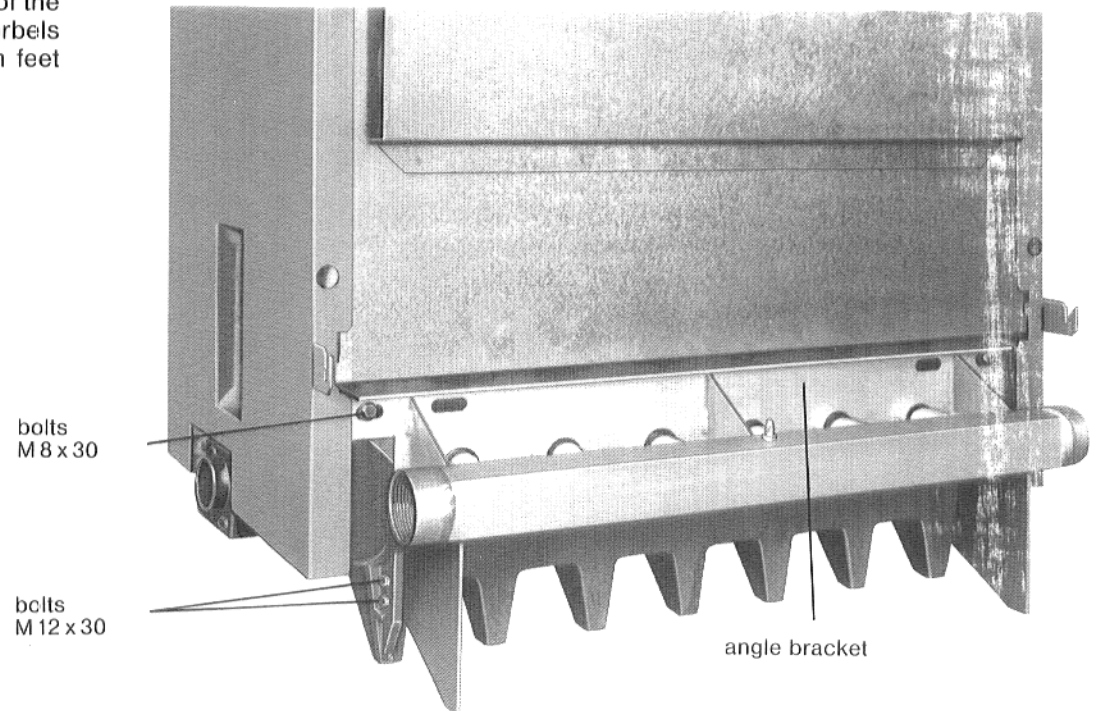


Fig. 28

5.10 Fittings

Depending on the fittings connection (right or left), seal the **connecting pipe** on the burner grid (Fig. 29).

If a leakage control device is supplied, a second solenoid valve is fitted for the connecting pipe on the burner grid (see Fig. 32 and 7.1 Valve leakage control).

Insert **inspection port flap** in combustion chamber safety plate „A“ (Figs. 29 and 31).

Install **fittings** with seal on the connecting pipe and hold up with support.

The support can be shortened to the right height by shortening on the thread (Fig. 29).

Depending on the type of gas, different pilot burners are used (see 5.4 – Combustion chamber safety plate).

Install the **pilot burner** on combustion chamber safety plate "A" with the washers supplied. Use the socket wrench supplied (Fig. 31).

Connect the **pilot gas line** firmly on the pilot gas valve on the gas connection (with cutting ring connection) (Figs. 29 and 31).

The upper part of the pilot gas valve must always be vertical (Fig. 31).

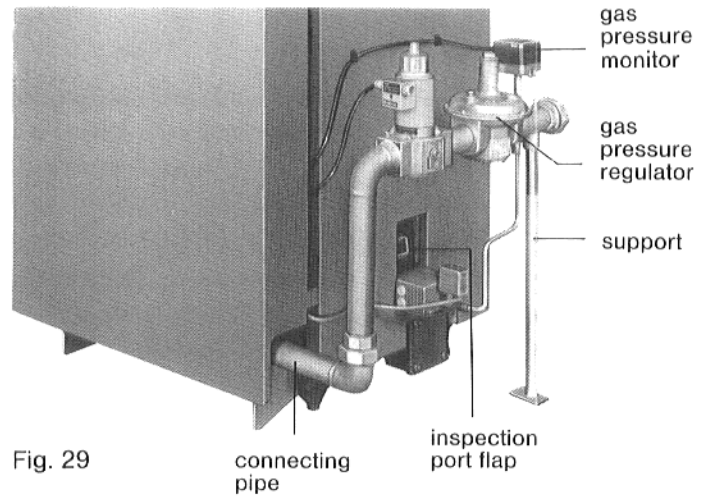


Fig. 29

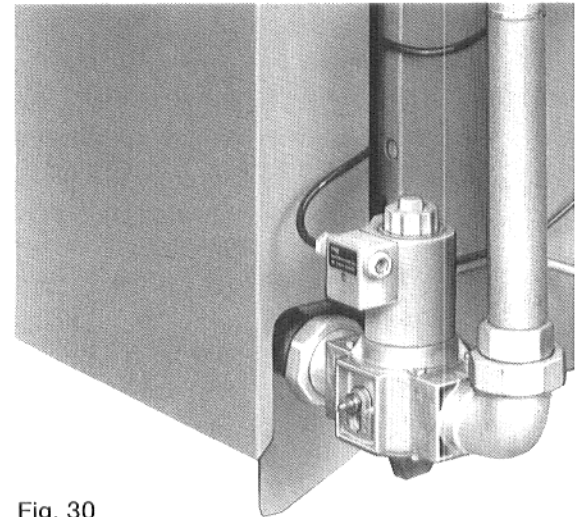


Fig. 30

Note:

In line with DIN 4702, for a nominal load >350 kW a second solenoid valve must be fitted (Fig. 30).

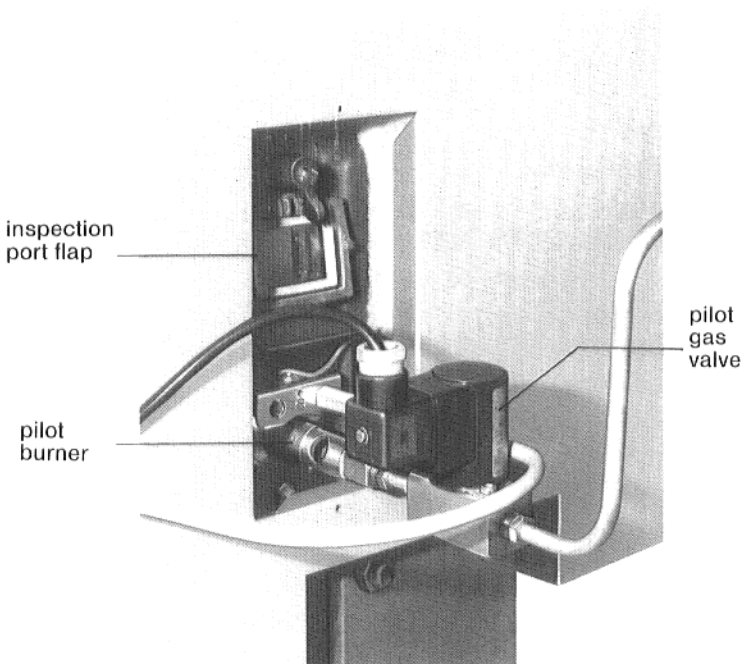


Fig. 31

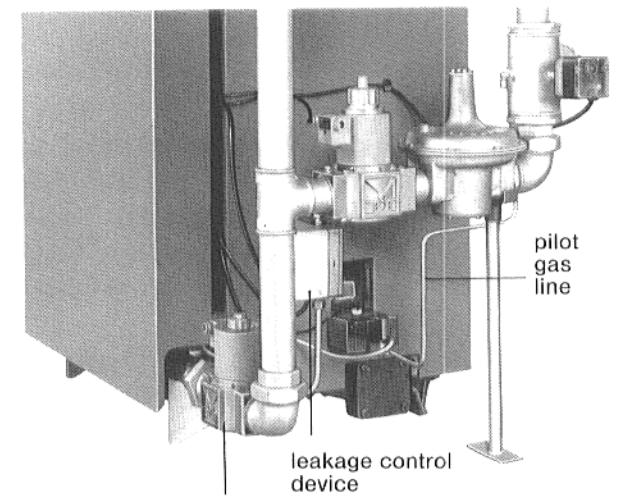


Fig. 32

6. Electrical installation

6.1 General

The G_424 LOWNOX boiler has the option of 2-stage operation.

With low temperature or conventional boiler circuit regulation.

With valve leakage control device and flue gas monitoring.

6.2 Electrical connection and installation of control panel

The boiler can be equipped with the control panels HS 3320 or HS 3321. The following illustrations show the installation of the HS 3320 control panel with in-built automatic boiler circuit control (Ecomatic control).

- Unscrew the two screws in the terminal cover (Fig. 34).
- Take off the terminal cover.
- Position the control panel on the front boiler hood in such a way that the push-in hooks on the underside of the control panel at the front enter the oval bores (see Fig. 35).

- Lay the capillary tube for the temperature sensor and, for Ecomatic control, the boiler water temperature sensor lead through the opening in the front boiler hood from the cable niche on the front of the boiler (see Fig. 36).
- Pull the control panel forward and push down simultaneously until the two elastic hooks click into place in the rear bores.

- * – thermostat (TR)
– safety limitstat (STB)
– thermometer
– boiler circuit sensor (only HS 3320)

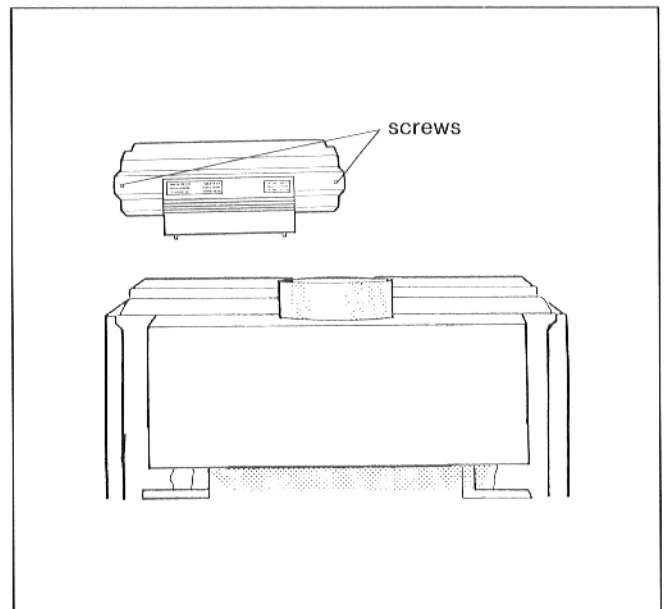


Fig. 34 – Rear view with terminal cover

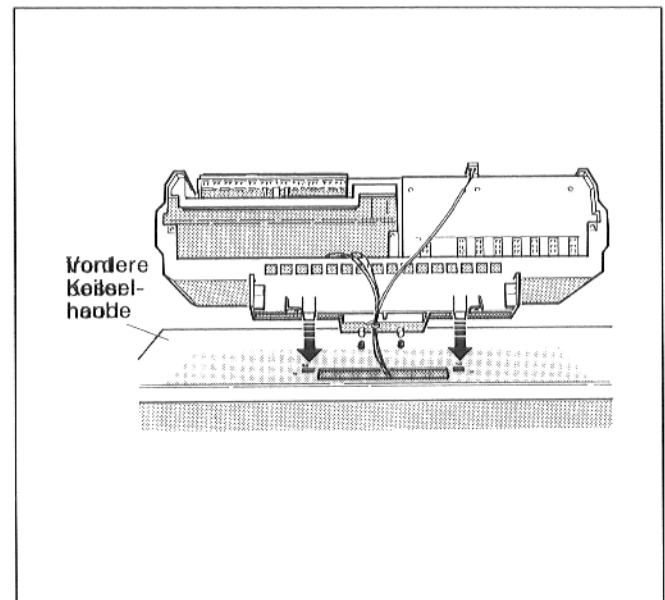


Fig. 35 – Positioning the control panel

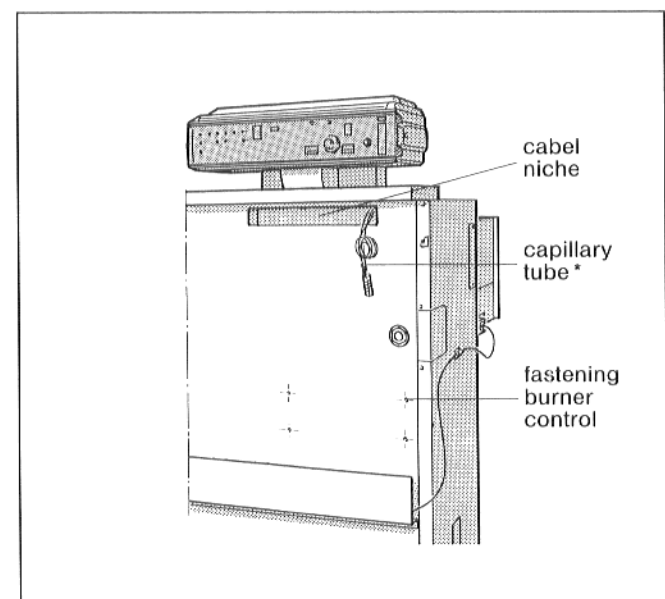


Fig. 36 – Front of boiler with front panel removed

- Fasten the control panel with two screws in the rear corners of the cable passageway on the boiler hood (Fig. 37).

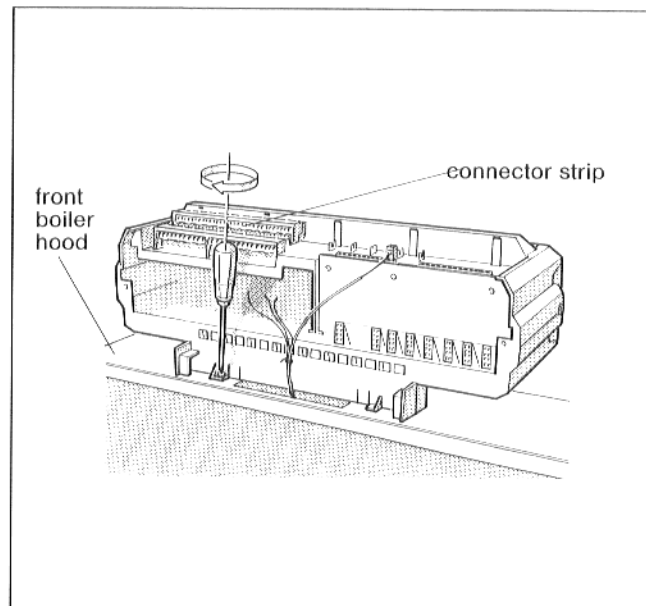


Fig. 37 – Rear of control panel with terminal cover removed

- Roll out the capillary tube and, for Ecomatic control, the boiler water temperature sensor lead until they reach to the measuring point (see Fig. 37).
- Push in temperature sensor into the sensor pocket (measuring point) to maximum extent (see Fig. 38). The plastic spiral is pushed back automatically. The compensating spring must also be pushed into the sensor pocket.
- Press the sensor fastener (scope of supply control panel) from the side or from above onto the head of the sensor pocket (see Fig. 39).

- * – thermostat (TR)
- safety limitstat (STB)
- thermometer
- boiler circuit sensor (only for HS 3320)

** – measuring point – on the right or left, but always on the side of the flow connection

*** – burner control can be fitted either on the right or, from size 209-13 upwards, on the left (here on the right)

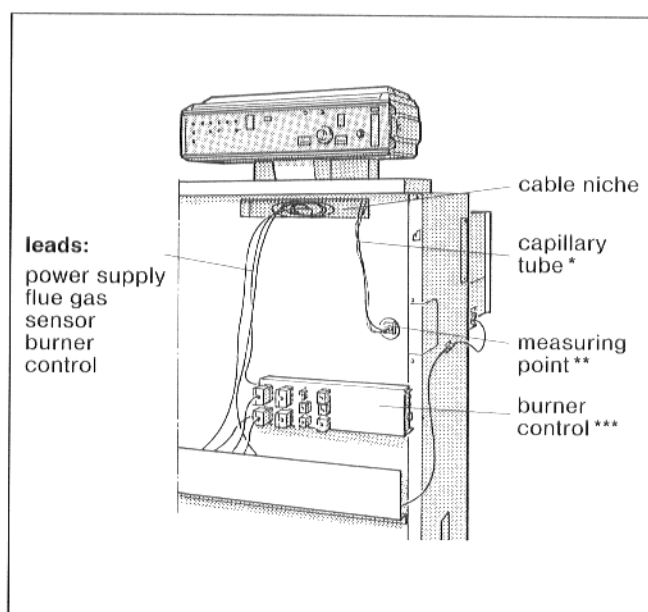


Fig. 38 – Front of boiler with front panel removed

- Mount the burner control with 4 self-tapping screws on the separating panel (see Figs. 36/38).
- Make on-site connections according to the circuit diagram to the plug connections in the control panel.
- The leads from the flue gas sensor, power supply and the burner control are laid via the cable niche and the opening in the boiler hood to the control panel.
- Make connections to the connector strip according to the circuit diagram.

The plugs can be levered off the connector strip with the aid of a screwdriver (see Fig. 37).

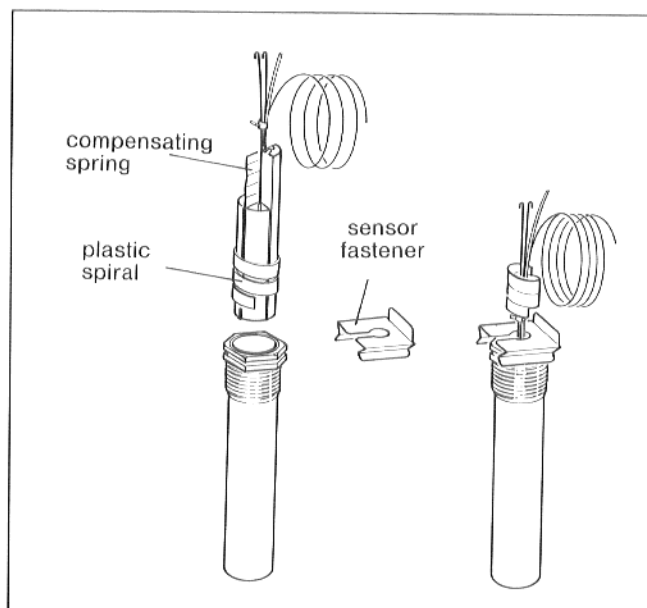


Fig. 39 – Sensor pocket

With the aid of the suitable cable clamp (scope of supply control panel), all leads can be fastened in the clip frame in the following way (see Figs. 40/41).

- Insert the cable clamp with the lead fitted from above into the slot of the clip frame. The lever must point upward. Push the cable clamp down and press against it. Push the lever upward to clamp (Fig. 41).
- Push excess length of the capillary tube and leads into the cable niche.
- Fasten the terminal cover on the control panel once again.

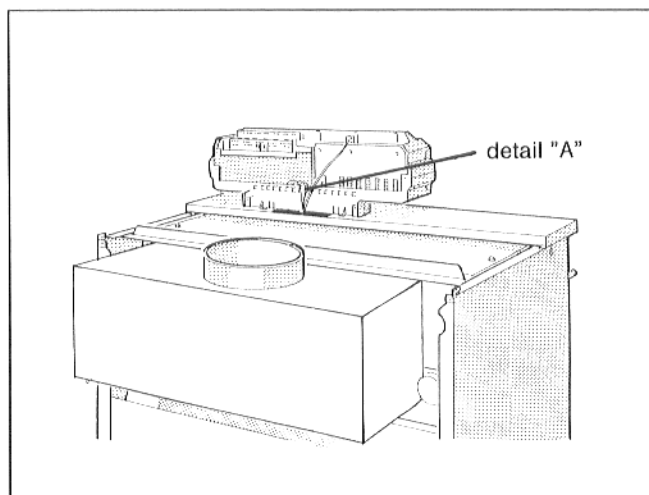


Fig. 40

- Lay the excess length of the leads in the cable passageway on the separating panel.

Special care must be taken that the cable does not come into contact with hot parts of the boiler or parts of the draught hood.

To avoid injury, all unprotected tips of self-tapping screws must be fitted with protective caps.

- A fixed connection must be made.

The boiler must be protected by a fuse with maximum 10 A.

Note: Plug no. 7 with bridge 2-3 must always be plugged except for leakage control device.

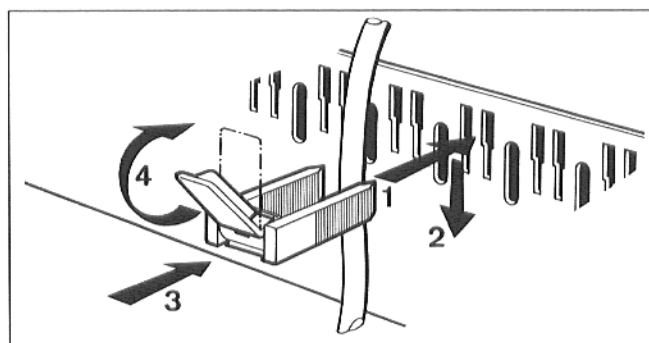


Fig. 41 - Detail "A" - cable clamp

- After all electrical connections have been laid, put on the rear boiler hood and fasten at the rear with the two fastening screws.
- Put the slot of the fastening screw for the transparent cover of the control panel into a horizontal position (e.g. with a coin) and push in the transparent cover from the front. Put the screw slot in a vertical position (see Fig. 45).
- Fit the front panel (front panels, resp.) on 4 (8 resp.) hooks (see Fig. 42).
- With the two screws supplied, the front panel is fastened in addition at the upper hooks (in the case of 2 front panels: upper external hooks).
- Mount the rating plate supplied (see Fig. 24, page 14).

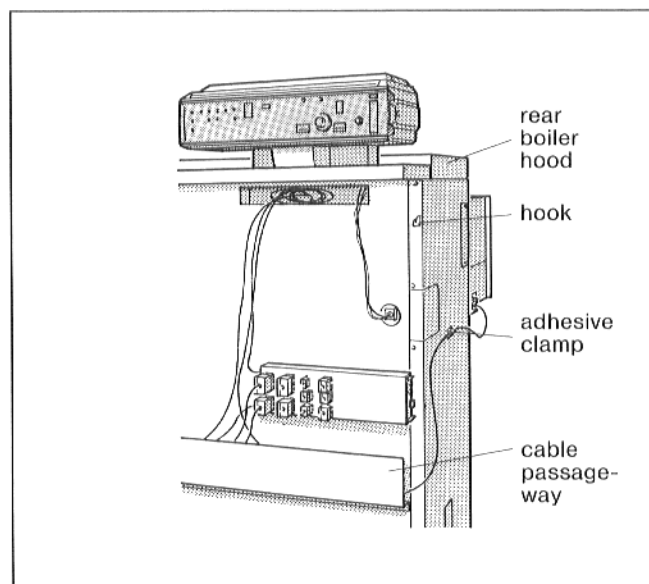


Fig. 42 - Boiler with rear boiler hood positioned

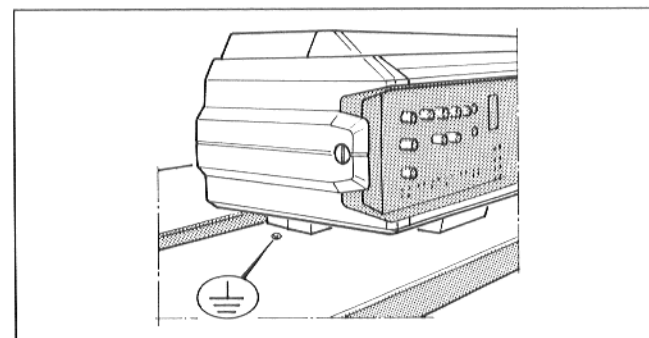


Fig. 43

6.3 Contact guard and pilot burner

Lay the **connection leads** to the pilot burner separately and fasten with adhesive clamps on the side panel.

Lay the **pilot cable** with firing transmitter from the burner control to the pilot burner (Fig. 44).

Make an **earth lead** connection to the firing transmitter.

Screw the **lower part of the contact guard** to the side panel with a self-tapping screw.

Poke the **connection leads** through the cable passageways in the upper part of the contact guard (Fig. 45).

Plug the **pilot cable** with the firing transmitter onto the pilot burner.

Connect the **pilot burner**.

Screw the **upper part of the contact guard** to the lower part with 2 fastening screws (Fig. 45).

Caution!

Take care that no cable in the contact guard comes into contact with hot cast iron parts.

Screw **monitoring electrode "2"** into the upper opening (LOWNOX) of the combustion chamber safety plate "B" (Fig. 46).

Pull the lead for the monitoring electrode "2" through the cable passageway in the side panel and plug onto monitoring electrode "2".

Screw the cover onto the side panel with self-tapping screws (Fig. 47).

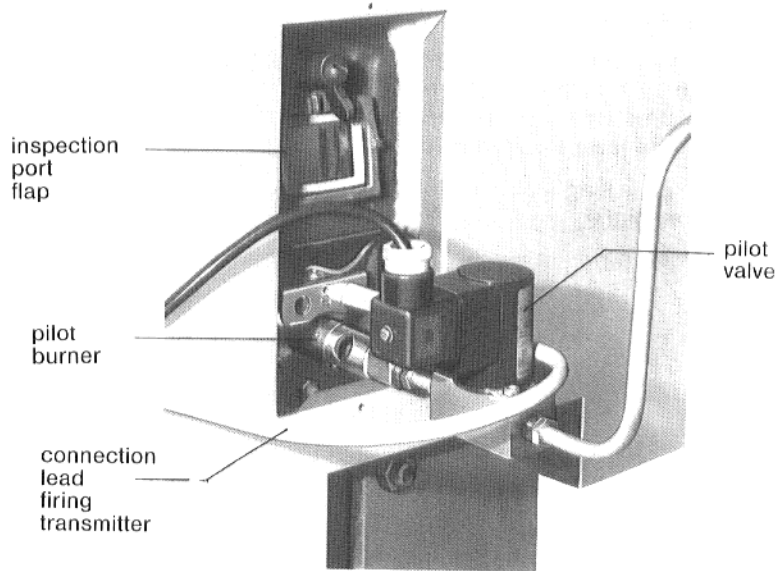


Fig. 44

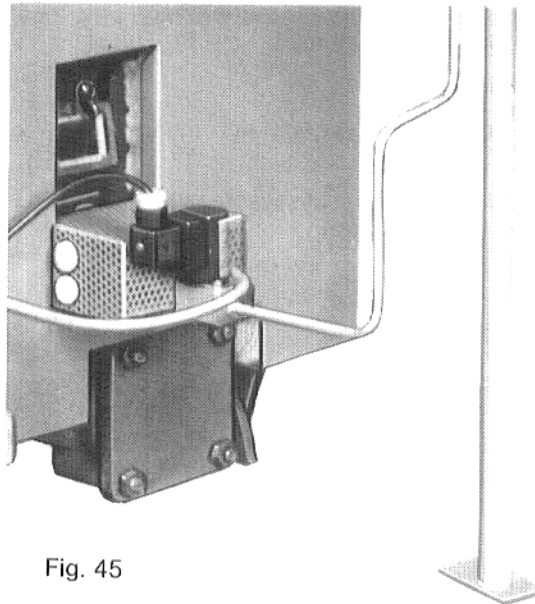


Fig. 45

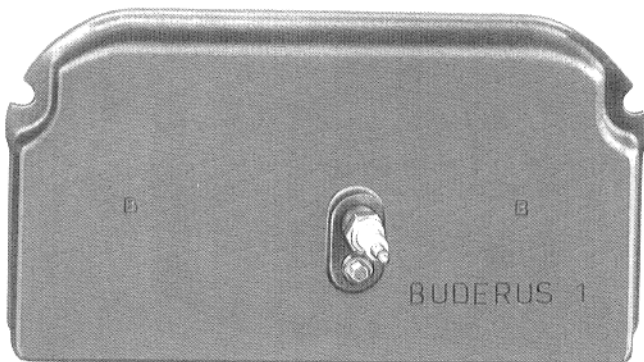


Fig. 46 – Combustion chamber safety plate "B"

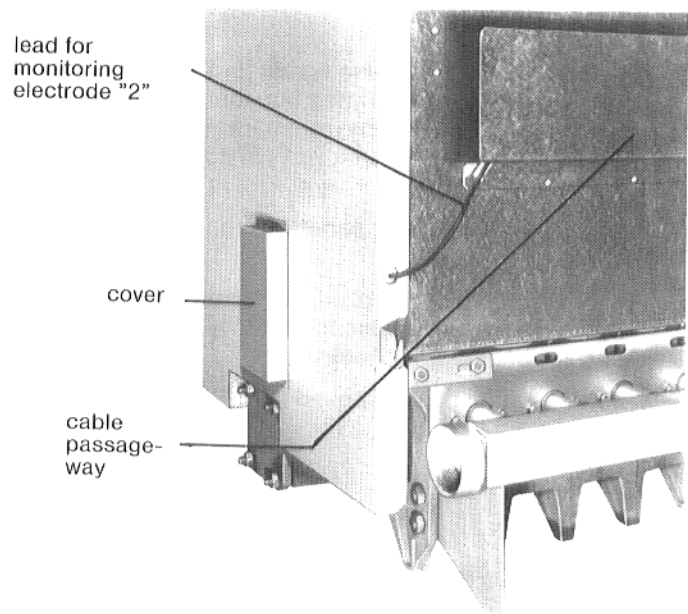


Fig. 47 – Schematic illustration

7. Accessories

7.1 Valve leakage control

Scope of supply:

2 straight screw connections
 upper and lower connection lead
 1 leakage control device VDK 200A
 with electrical connection ready to plug in
 1 solenoid valve

Assembly sequence:

Install **solenoid valve** between the burner grid and the gas pipeline.

Insert seals.

Unscrew **blind plugs** with Allen screw on the insides of the main gas solenoid valve and the solenoid valve.

Seal inserted end **screw connections** into the solenoid valve and the main gas solenoid valve.

Push the short arm (110 mm) of the **lower connection line** into the inserted end screw connections and join.

The long arm (180 mm) must point upward.

Put the **VDK 200 A** on the lower connection lead and screw together.

Adapt the **second connection line** between the VDK 200 A and the main gas solenoid valve (shorten if necessary) and screw together with both.

The electrical connection to the burner control is made according to the circuit diagram with a plug connection.

See also Section 5.10 – Fittings.

After assembling, the installation must be tested for gas leakage.

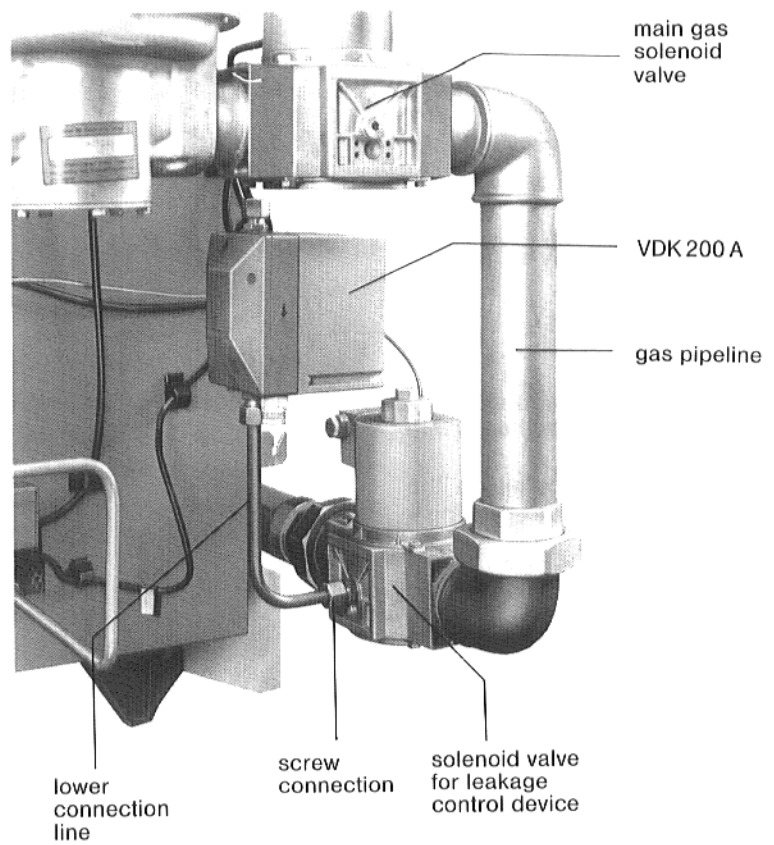


Fig. 48 – Schematic illustration

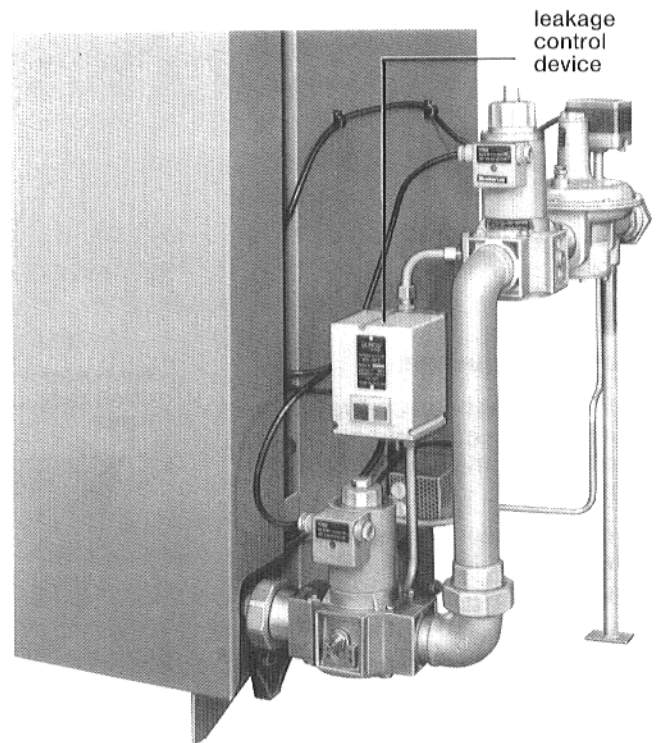


Fig. 50

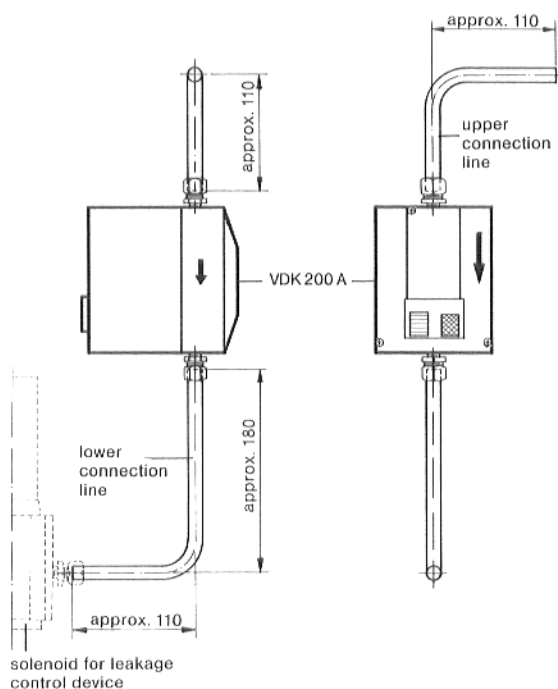


Fig. 49

7.2 Flue gas blocking flap

The flue gas blocking flap must be fitted on site before assembling the draught hood.

Caution!

The servo-motor can only be fitted on the right.

Scope of supply:

flue gas blocking flap with counterweights and front panel on the left with bearing pin – item 1.

drive shaft with front panel on the right, cover plate and drive coupling – item 2.

holding bracket with distance bolts – item 3

cover plate left – item 4

The holding bracket is already assembled with the drive shaft, spacer bolts and the front panel in the factory.

motor ST 7.2 with connection lead ready to plug in

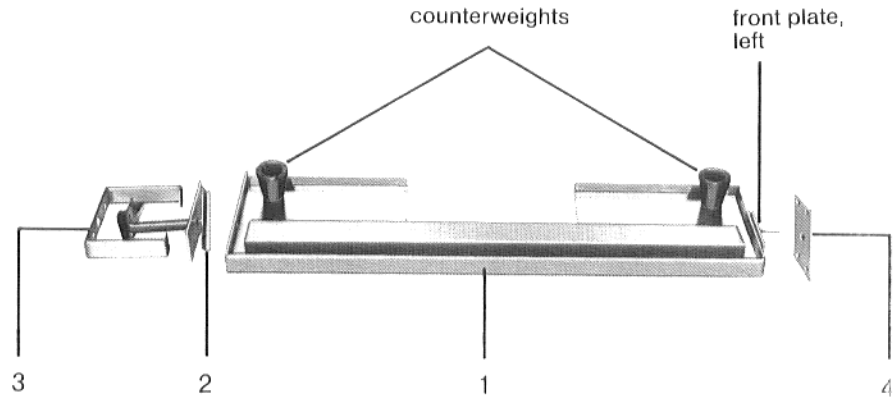


Fig. 51

Assembly sequence:

Lay the **draught hood** on two lengths of timber (flue gas connection and cleaning openings pointing downward) (Fig. 52).

Remove the **cover plates fitted in the factory** on the left and right of the draught hood (no longer needed).

Fasten the **cover plate** with the bore on the left with 4 self-tapping screws (Fig. 52).

Hold the **flue gas blocking flap** at an angle in the draught hood and poke the bearing pin of the left-hand front panel through the bore in the left-hand cover plate (Fig. 52).

Caution!

Take care to position the flue gas flap correctly.

In this position (Fig. 52), the counterweights must point upward.

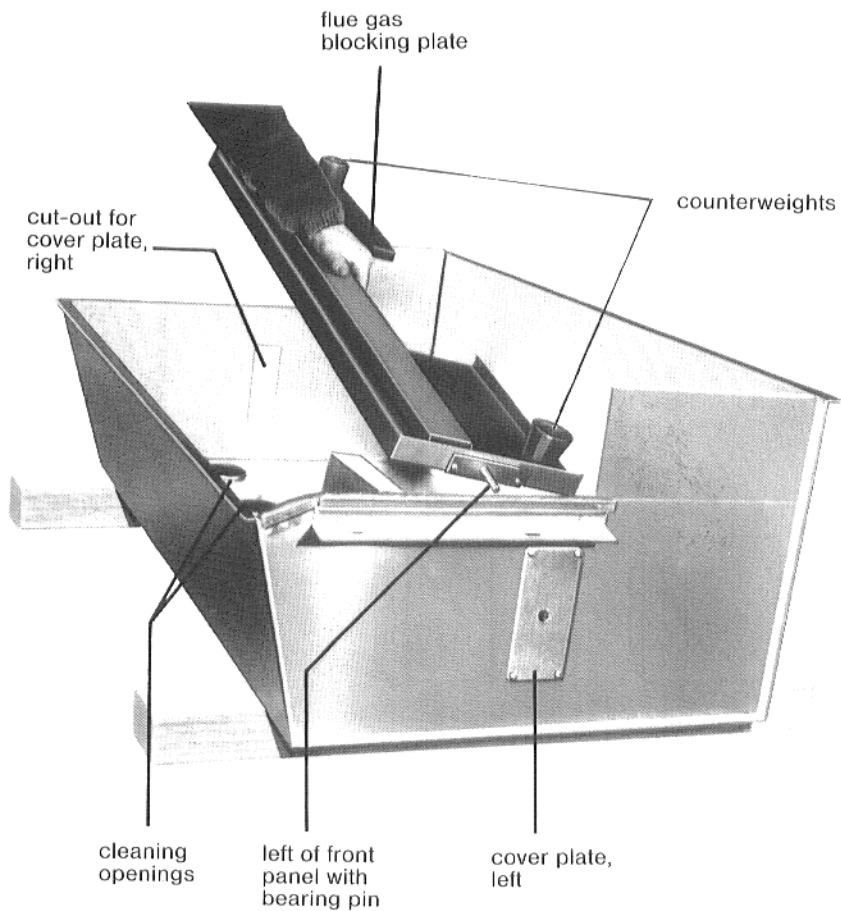


Fig. 52 – Schematic illustration

Put the flue gas blocking flap in a vertical position (Fig. 53).

In this position, the counterweights of the flue gas blocking flap must point towards the rear.

The **front panel** and **cover plate** must be perpendicular to each other.

Poke the **front panel** in the position through the right-hand side panel of the draught hood and screw onto the flue gas blocking flap with 2 self-tapping screws (Fig. 53).

Turn the **cover plate** further through 90° and mount on the side panel of the draught hood with 4 self-tapping screws (Fig. 54).

Adjust the **driving plate** with the aid of the **hand lever** in such a way that the **drive motor** can be set onto the retaining bolts on the drive block.

Push on the **drive motor**, fasten top and bottom with the retaining bolts and lock with the safety nuts (Fig. 55).

Lay the **connection cable** on the side panel up to the cable passageway (on the separating panel) and fasten with adhesive clamps.

Note:

Remove blind plug ⑧. It is no longer needed.

Make a connection in the control panel according to the circuit diagram (see Sec. 6.2).

Lay excess length in the cable passageway.

Caution!

1. If the servo-motor is removed, the flap must be in the „open“ position.
2. Check the flap for proper functioning: The burner may only go into operation with the flap opened completely.

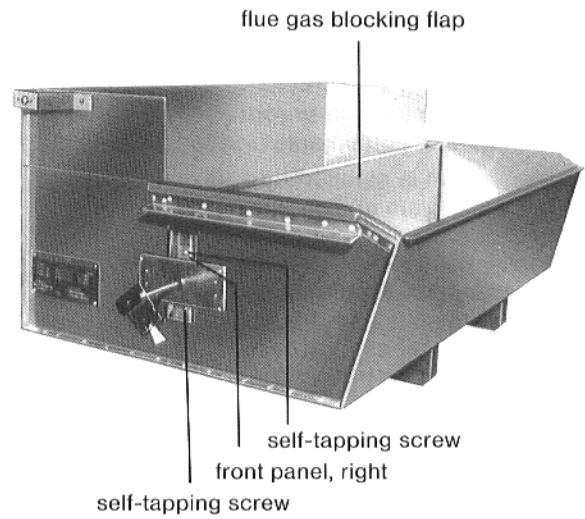


Abb. 53 – Schematic illustration

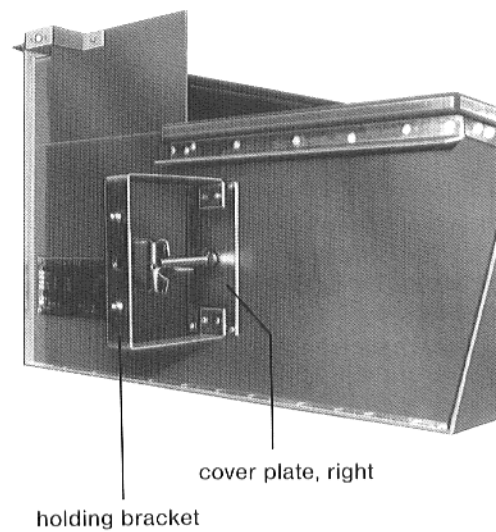


Fig. 54 – Schematic illustration

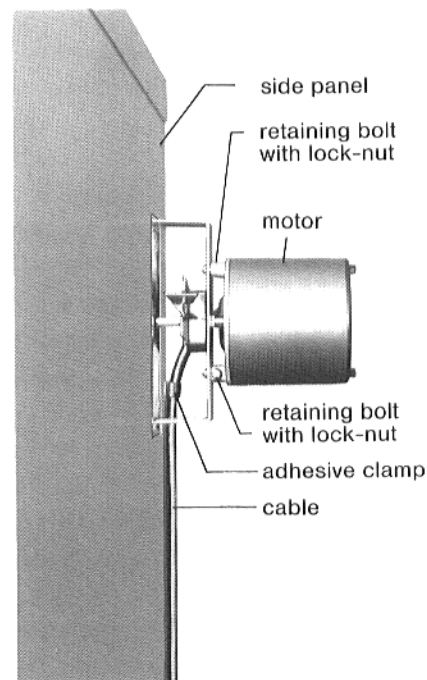


Fig. 55 – Schematic diagram

7.3 Flue gas monitoring

The flue gas monitoring is **only** installed in boilers that are located in **roof boiler rooms** (special equipment).

If the flue gas stream is blocked by a blockage or backstream in the chimney, the flue gas streaming out of the draught hood warms up the sensor of the flue gas monitoring. Depending on the proportion of the flue gas streaming out, the flue gas monitoring switches the gas supply to the burner after a set time has run out.

Scope of supply:

- flue gas monitoring module 065 consisting of module 065 and flue gas temperature sensor
- bag with installation material
- assembly instructions for inserting and removing modules and for the temperature sensor for flue gas monitoring module 065.

Assembly and function check:

- Insert control panel module 065 according to the installation instructions provided for inserting and removing modules.
- Insert the flue gas sensor loosely in the bracket on the draught hood.
- Fit sensor cable with adhesive clamps on the side panel and connect in the control panel according to the circuit diagram.

The function check must be carried out at initial start-up as well as at recommended boiler maintenance periods by a specialist technician.

Carry out the test as follows:

- Put the boiler water thermostat to maximum temperature. For Eco-matic control, press the chimney sweep button.
- Hold the tip of the flue gas temperature sensor in the core of the flue gas stream.
- After a brief period (max. 120 sec.), the flue gas monitoring should have switched the burner off.
- After a switch-off interval of about 3 minutes, the burner is switched on again automatically if heating is still required.
- After a successful test, introduce the flue gas sensor through the bracket on the draught hood and fasten with the 2 screws supplied.

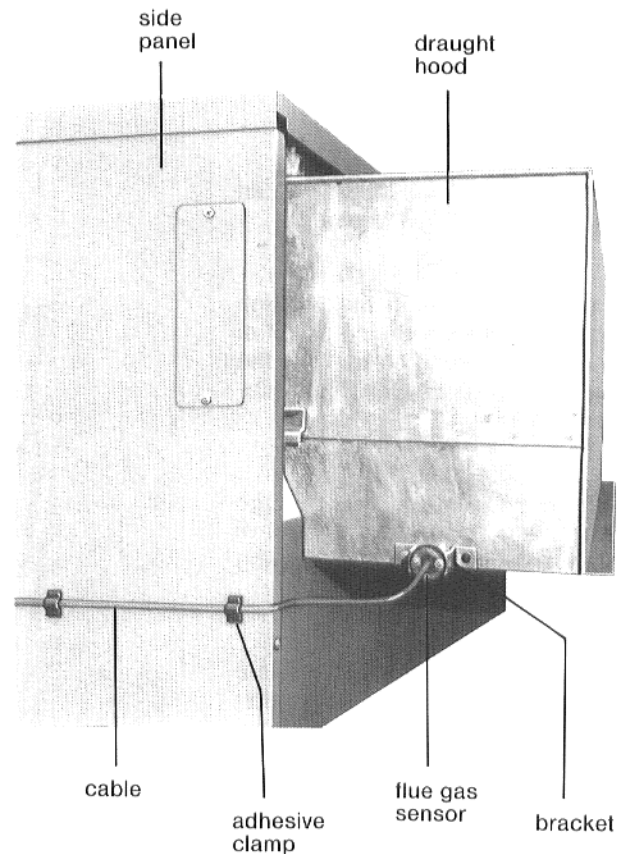


Fig. 56 – Schematic illustration

